



Avant-projet de norme soumis à enquête probatoire jusqu'au :

20 MARS 2005

Pr NF EN ISO 18233

Indice de classement : S 31-908

T1 Acoustique

T2 Utilisation de nouvelles méthodes de mesurage dans l'acoustique des bâtiments et des pièces

T3

E : Acoustics – Application of new measurement methods in building and room acoustics

D :

Avant-projet de norme française homologuée

Remplace :

Correspondance

Analyse

Modifications

Norme française

NF EN ISO 18233

Indice de classement : S 31-908

ICS : 91.120.20

T1 Acoustique

T2 Utilisation de nouvelles méthodes de mesurage dans l'acoustique des bâtiments et des pièces (ISO/DIS 18233 : 2004)

T3

E : Acoustic — Application of new measurement methods in building and room acoustics (ISO/DIS 18233: 2004)

D : Akoustik — (ISO/DIS 18233 : 2004)

Norme française homologuée par décision du Directeur Général d'AFNOR le pour prendre effet le .

Correspondance

La norme européenne EN ISO 18233 : 200X a le statut d'une norme française.

Analyse

Le présent document fournit des éléments et spécifie l'ensemble des conditions nécessaires pour l'application de nouvelles méthodes de mesurage des propriétés acoustiques des bâtiments et éléments de bâtiment.

Le présent document est utilisé pour les mesure de l'isolation au bruit aérien des façades ou entre pièces, la mesure du temps de réverbération et les autres paramètres acoustiques des pièces, , , et pour la mesure des différences de niveau de vibration ainsi que du facteur de perte de masse.

Cette norme internationale est applicable à une telle mesure comme l'isolation saine aéroportée entre les salles et des façades, de la mesure du temps de réverbération et d'autres paramètres acoustiques des salles, mesure d'absorption saine dans des salles d'une réverbération

Descripteurs

Thésaurus International Technique :

Modifications

Corrections

E:\AAARUTMAN\AAAnnée 2003\Dossiers projets et normes\Acoustique\NF_EN_ISO_18233_(2004-12)F.doc

Membres de la commission de normalisation

Président : M REHFELD

Secrétariat : M RUTMAN – BNTB

M	AFLALO	BRUEL et KJAER
M	ARCE	BRUEL et KJAER
MME	ARNAUD	SMAC ACIEROID
MME	BECKER	AFNOR
M	BENJELLOUN	CTTB
M	BERNARD	MINISTERE DE LA DEFENSE - STBFT
MME	BESSEYRIAS	SOLLAC LORRAINE
M	BRIDIER	SNFA
M	CHATELAIN	STR PVC
M	CHENE	CSTB
M	CHEVALDONNET	UNION DES INDUSTRIES DU BOIS
M	CYROT	SNI
M	DUTILLEUX	LRPC Strasbourg
M	FRANCOIS-BRAZIER	SAINT-GOBAIN PAM
M	GAMBA	ACOUSTIQUE GAMBA ET ASSOCIES
MME	GAULUPEAU	BUREAU VERITAS
M	GUILBERT	FILMM - SAINT-GOBAIN ISOVER
M	HAJEWSKI	TARKETT SAS
M	HUGUES	ALPHACAN SRA
M	LECOCQ	CIAL
M	LOUWERS	IMPEDANCE SA
M	MEISSER	SNI
M	OZOUF	SNPA - BPB-PLACO

M	PERSUY	SNPA
M	PINCON	BNTEC
M	REHFELD	CSFVP - SAINT GOBAIN GLASS
M	REIGNER	CEBTP
M	ROLAND	CSTB
M	SAUVAGE	CERIB
M	SERVANT	SOCOTEC
MME	SOULIER	METLTM - DGUHC
M	TISSEYRE	TISSEYRE ET ASSOCIES
M	TIZIANEL	LAFARGE PLATRES
M	VALENTIN	MINISTERE DE L'ENVIRONNEMENT - Mission BRUIT
M	VAN DEN BERGHE	FILMM – ROCKWOOL
M	VAYSSIE	FILMM - OWENS CORNING ALCOPOR
MME	VILLENAVE	CTBA
M	VILLOT	CSTB

Avant-propos

Références aux normes françaises

La correspondance entre les normes mentionnées à l'article "Références normatives" et les normes françaises identiques est la suivante :

ISO 140*	NF EN ISO 140*	(indice de classement : S 31-049)*
CEI 61260	NF EN 61260	(indice de classement : C 97-010)
CEI 61672-1	NF EN 61672-1	(indice de classement : S 31-009-1)

* toutes les parties

December 2004

ICS

English version

Acoustics - Application of new measurement methods in building and room acoustics (ISO/DIS 18233:2004)

Acoustique - Utilisation de nouvelles méthodes de
mesurage dans l'acoustique des bâtiments et des pièces
(ISO/DIS 18233:2004)

This draft European Standard is submitted to CEN members for parallel enquiry. It has been drawn up by the Technical Committee CEN/TC 126.

If this draft becomes a European Standard, CEN members are bound to comply with the CEN/CENELEC Internal Regulations which stipulate the conditions for giving this European Standard the status of a national standard without any alteration.

This draft European Standard was established by CEN in three official versions (English, French, German). A version in any other language made by translation under the responsibility of a CEN member into its own language and notified to the Management Centre has the same status as the official versions.

CEN members are the national standards bodies of Austria, Belgium, Cyprus, Czech Republic, Denmark, Estonia, Finland, France, Germany, Greece, Hungary, Iceland, Ireland, Italy, Latvia, Lithuania, Luxembourg, Malta, Netherlands, Norway, Poland, Portugal, Slovakia, Slovenia, Spain, Sweden, Switzerland and United Kingdom.

Warning : This document is not a European Standard. It is distributed for review and comments. It is subject to change without notice and shall not be referred to as a European Standard.



EUROPEAN COMMITTEE FOR STANDARDIZATION
COMITÉ EUROPÉEN DE NORMALISATION
EUROPÄISCHES KOMITEE FÜR NORMUNG

Management Centre: rue de Stassart, 36 B-1050 Brussels

Foreword

This document (prEN ISO 18233:2004) has been prepared by Technical Committee ISO/TC 43 "Acoustics" in collaboration with Technical Committee CEN/TC 126 "Acoustic properties of building elements and of buildings", the secretariat of which is held by AFNOR.

This document is currently submitted to the parallel Enquiry.

Endorsement notice

The text of ISO 18233:2004 has been approved by CEN as prEN ISO 18233:2004 without any modifications.



DRAFT INTERNATIONAL STANDARD ISO/DIS 18233

ISO/TC 43/SC 2

Secretariat: DIN

Voting begins on:
2004-12-16

Voting terminates on:
2005-05-16

INTERNATIONAL ORGANIZATION FOR STANDARDIZATION • МЕЖДУНАРОДНАЯ ОРГАНИЗАЦИЯ ПО СТАНДАРТИЗАЦИИ • ORGANISATION INTERNATIONALE DE NORMALISATION

Acoustics — Application of new measurement methods in building and room acoustics

Acoustique — Utilisation de nouvelles méthodes de mesurage dans l'acoustique des bâtiments et des pièces

ICS 91.120.20

ISO/CEN PARALLEL ENQUIRY

The CEN Secretary-General has advised the ISO Secretary-General that this ISO/DIS covers a subject of interest to European standardization. **In accordance with the ISO-lead mode of collaboration as defined in the Vienna Agreement, consultation on this ISO/DIS has the same effect for CEN members as would a CEN enquiry on a draft European Standard.** Should this draft be accepted, a final draft, established on the basis of comments received, will be submitted to a parallel two-month FDIS vote in ISO and formal vote in CEN.

In accordance with the provisions of Council Resolution 15/1993 this document is circulated in the English language only.

Conformément aux dispositions de la Résolution du Conseil 15/1993, ce document est distribué en version anglaise seulement.

To expedite distribution, this document is circulated as received from the committee secretariat. ISO Central Secretariat work of editing and text composition will be undertaken at publication stage.

Pour accélérer la distribution, le présent document est distribué tel qu'il est parvenu du secrétariat du comité. Le travail de rédaction et de composition de texte sera effectué au Secrétariat central de l'ISO au stade de publication.

THIS DOCUMENT IS A DRAFT CIRCULATED FOR COMMENT AND APPROVAL. IT IS THEREFORE SUBJECT TO CHANGE AND MAY NOT BE REFERRED TO AS AN INTERNATIONAL STANDARD UNTIL PUBLISHED AS SUCH.

IN ADDITION TO THEIR EVALUATION AS BEING ACCEPTABLE FOR INDUSTRIAL, TECHNOLOGICAL, COMMERCIAL AND USER PURPOSES, DRAFT INTERNATIONAL STANDARDS MAY ON OCCASION HAVE TO BE CONSIDERED IN THE LIGHT OF THEIR POTENTIAL TO BECOME STANDARDS TO WHICH REFERENCE MAY BE MADE IN NATIONAL REGULATIONS.

PDF disclaimer

This PDF file may contain embedded typefaces. In accordance with Adobe's licensing policy, this file may be printed or viewed but shall not be edited unless the typefaces which are embedded are licensed to and installed on the computer performing the editing. In downloading this file, parties accept therein the responsibility of not infringing Adobe's licensing policy. The ISO Central Secretariat accepts no liability in this area.

Adobe is a trademark of Adobe Systems Incorporated.

Details of the software products used to create this PDF file can be found in the General Info relative to the file; the PDF-creation parameters were optimized for printing. Every care has been taken to ensure that the file is suitable for use by ISO member bodies. In the unlikely event that a problem relating to it is found, please inform the Central Secretariat at the address given below.

Copyright notice

This ISO document is a Draft International Standard and is copyright-protected by ISO. Except as permitted under the applicable laws of the user's country, neither this ISO draft nor any extract from it may be reproduced, stored in a retrieval system or transmitted in any form or by any means, electronic, photocopying, recording or otherwise, without prior written permission being secured.

Requests for permission to reproduce should be addressed to either ISO at the address below or ISO's member body in the country of the requester.

ISO copyright office
Case postale 56 • CH-1211 Geneva 20
Tel. + 41 22 749 01 11
Fax + 41 22 749 09 47
E-mail copyright@iso.org
Web www.iso.org

Reproduction may be subject to royalty payments or a licensing agreement.

Violators may be prosecuted.

Contents

Page

Foreword.....	v
Introduction.....	v
1 Scope	1
2 Normative references	1
3 Terms and definitions	1
4 General theory	2
4.1 General	2
4.2 Sound in a room	2
4.3 Sound transmission between two rooms	5
4.4 Using the frequency response function	5
5 Measurement of the impulse response	6
5.1 General	6
5.2 Excitation signal	7
5.2.1 General	7
5.2.2 Spectral requirements	7
5.2.3 Level and linearity	8
5.2.4 Directivity	8
5.2.5 Number of source positions	8
5.3 Measurement of the response	8
5.3.1 Transducers for measurement	8
5.3.2 Frequency weighting	9
5.3.3 Level linearity and dynamic range	9
5.3.4 Crosstalk	9
5.3.5 Limits for the time integration	10
5.3.6 Response averaging	12
5.3.7 Number of measurement points and spatial averaging	12
5.3.8 Stability and time-invariance	12
5.3.9 Environmental conditions	13
5.3.10 Calibration and check of accuracy	13
6 Measurement of the frequency response function	14
7 Precision	14
8 Test report	14
Annex A (normative) Maximum Length Sequence Method	15
A.1 General	15
A.2 Sequence length	16
A.3 Signal-to-noise ratio	16
A.3.1 General	16
A.3.2 Level measurements	17
A.3.3 Measurement of reverberation time	17
A.4 Time invariance	17
A.4.1 General	17
A.4.2 Movement	17
A.4.3 Environmental conditions	18
A.4.4 Distortion	18
Annex B (normative) Swept-Sine Method	19
B.1 General	19
B.2 Sweep duration	19

B.3	Sweep Generation	20
B.3.1	General	20
B.3.2	Sweeps with white and pink spectrum	20
B.3.3	Synthesis of sweeps with arbitrary amplitude spectrum	20
B.4	Recording the response	21
B.5	Deconvolution	21
B.6	Signal-to-noise ratio	23
B.7	Time invariance	23
B.7.1	General	23
B.7.2	Movement	24
B.7.3	Environmental conditions	24
B.7.4	Distortion	24
B.8	Periodic and repeated sweeps	24
	Bibliography	25

Foreword

ISO (the International Organization for Standardization) is a worldwide federation of national standards bodies (ISO member bodies). The work of preparing International Standards is normally carried out through ISO technical committees. Each member body interested in a subject for which a technical committee has been established has the right to be represented on that committee. International organizations, governmental and non-governmental, in liaison with ISO, also take part in the work. ISO collaborates closely with the International Electrotechnical Commission (IEC) on all matters of electrotechnical standardization.

International Standards are drafted in accordance with the rules given in the ISO/IEC Directives, Part 2.

The main task of technical committees is to prepare International Standards. Draft International Standards adopted by the technical committees are circulated to the member bodies for voting. Publication as an International Standard requires approval by at least 75 % of the member bodies casting a vote.

Attention is drawn to the possibility that some of the elements of this document may be the subject of patent rights. ISO shall not be held responsible for identifying any or all such patent rights.

ISO 18233 was prepared by Technical Committee ISO/TC 43, *Acoustics*, Subcommittee SC 2, *Building Acoustics*.

Introduction

Stochastic signal analysis methods for the measurement of sound transmission phenomena started to be developed around 1960, but lack of available computing power excluded the use of these methods outside the most equipped research laboratories.

The development of digitising circuitry, powerful personal computers and the use of digital signal processing components in sound measuring equipment for field use, have made the application of measuring equipment based on extended digital signal analysis readily available. Dedicated instruments, as well as specialised software used on general computers, are currently applying such methods and already widely used.

The new methods bring a number of advantages compared to the well-established classical methods such as suppression of background noise and extended measurement range. However, there is also risk of unreliable results if certain guidelines are not followed. The new methods may demonstrate larger sensitivity to time-variations and change in the environmental conditions than the classical methods.

This International Standard is developed to give requirements and guidelines for the use of new measurement methods in building acoustic measurements, but may also be used in the construction of measuring equipment for the implementation of the methods.

As even an experienced user of equipment based on classical methods may be unaware of the difficulties and limitations for some applications of the new methods, the user should be encouraged to develop a deeper understanding of the theoretical bases for the new methods. Instrument manufacturers should give further guidelines for applications and should make it an objective to design instruments that give warnings when results are not reliable.

This International Standard gives guidelines and requirements for application of new measurements methods for the measurement of sound insulation in buildings and building elements and for the measurement of reverberation time and related quantities.

Acoustics — Application of new measurement methods in building and room acoustics

1 Scope

This International Standard gives guidelines and specifies requirements for application of new measurement methods for the measurement of acoustic properties of buildings and building elements. Guidelines and requirements for selection of excitation signal, signal processing and environmental control are given together with requirements for linearity and time-invariance for the systems to be tested.

This international standard is applicable to such measurement as airborne sound insulation between rooms and of façades, measurement of reverberation time and other acoustic parameters of rooms, measurement of sound absorption in a reverberation rooms and for the measurement of vibration level differences and loss factor.

2 Normative references

The following referenced documents are indispensable for the application of this document. For dated references, only the edition cited applies. For undated references, the latest edition of the referenced document (including any amendments) applies.

ISO 140 (all parts), *Acoustics – Measurement of sound insulation in buildings and building elements* .

IEC 61260, *Electroacoustics – Octave-band and fractional-octave-band filters* .

IEC 61672-1, *Electroacoustics – Sound level meters – Part 1: Specifications*.

3 Terms and definitions

For the purposes of this document, the following terms and definitions apply.

3.1

classical method

conventional method of measurement where the resulting levels or decay times are determined directly from the recorded responses to random noise or impulse signals

3.2

new method

measurement method in which various deterministic signals can be used to first obtain the impulse response of the system under test and from which the required levels and decay times can be obtained

NOTE The new method may have additional, intentional features such as deliver results under situations where no result is obtained by the classical method. The new method may for instance be more immune to noise from other sources.

3.3 effective signal-to-noise ratio
Twenty times the logarithm, base ten, of the ratio of the root-mean-square value of the signal part caused by the excitation and obtained by the new method, to the root-mean-square value of the unwanted part of the signal obtained by the same method and caused by other sources than the excitation. The effective signal-to-noise ratio is given in decibels.

NOTE The effective signal to noise ratio is used as a substitute for the normal signal-to-noise ratio when establishing procedures for the new method based on a classical method. The abbreviation signal-to-noise ratio is also used.

3.4 peak-to-noise ratio
Twenty times the logarithm, base ten, of the ratio of the peak value of the signal part caused by the excitation and obtained by the new method, to the root-mean-square value of the unwanted part of the signal obtained by the same method and caused by other sources than the excitation. The peak-to-noise ratio is given in decibels.

3.5 fractional-octave-band
frequency range, in hertz, from lower to higher band-edge frequency for a fractional-octave-band filter as specified in IEC 61260

NOTE Both full octave- and fractional-octave-band filters are designated *fractional-octave-band filters*

4 General theory

4.1 General

The transmission of sound within a room as well as the transmission of sound between rooms may normally be regarded as a close approximation to a linear and time invariant system. The general theory applicable for such systems may therefore be used to establish the relationship between excitation and response for the sound transmission.

The impulse response is the basis of all measurements. The methods are applicable to the velocities measured on structures as well as to sound pressures measured in rooms.

4.2 Sound in a room

The scope of the International Standards ISO 140-3 to -5 and ISO 140-9 to -12 is to specify methods to measure the airborne sound insulation for building elements and the insulation between dwellings. In order to measure these quantities, the level and the reverberation time in rooms by the application of noise excitation shall be measured. For the measurement of reverberation time the noise source is switched on for a time sufficient to obtain a steady level. The source is thereafter switched off, and the decay of the sound in the room is observed. Without loss of generality, the time for switching the noise off is set to $t = 0$ in this International Standard.

A recording of the level versus time will in general contain information on the obtained stationary noise level in the room as well as the reverberation time. A typical level versus time diagram is shown in Figure 1. The stationary noise level before the noise is switched off is given by the recording for $t < 0$, and information about the decay will be given for $t \geq 0$. The decay may be further processed to obtain the reverberation time.

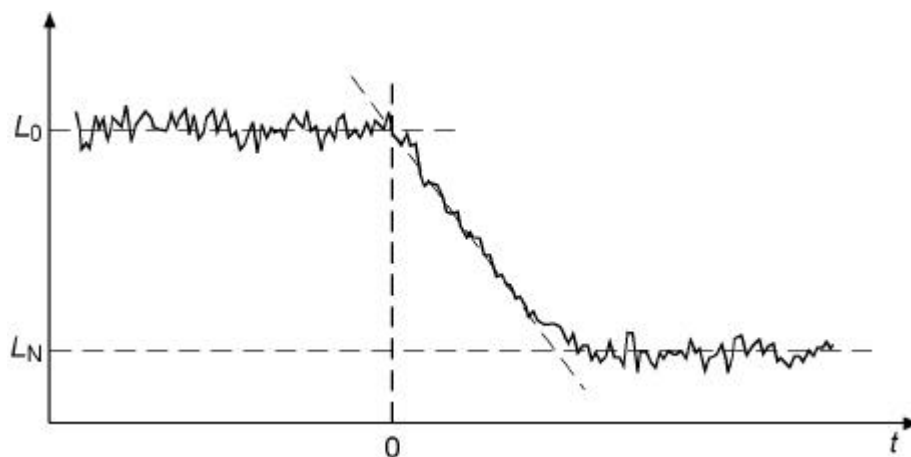

Key

L_0 stationary noise level before the excitation is switched off

L_N background noise level

t time

Note 1 The excitation is switched off at time $t = 0$

Figure 1 — Typical level versus time curve

The classical methods for the measurement of airborne sound in rooms, defined in the ISO 140-series of International Standards specify a stochastic signal for the excitation. Although the room in most cases may be described as a deterministic system, statistical spread from the random excitation will lead to a certain

stochastic variation in the result, which may be characterised by a standard deviation. Therefore, averaging of more measurements is normally needed to obtain results close to the stochastically expected values. Such averaging may for the classical method be combined with the spatial averaging needed to obtain a mean value for the room.

The methods described in this International Standard intend to obtain measurement values in fractional-octave-bands. Requirements and guidelines are selected accordingly.

Figure 2 gives an illustration of the difference between classical and new methods.

M.R. Schroeder [1] has shown that the expected decay in one particular observation point may be obtained without averaging by processing the impulse response between the excitation signal (loudspeaker) and the observation point (microphone) directly. This holds for the decay curve and the stationary levels as long as the system is linear and time-invariant. The theory may be extended and applied to sound in the source room, to sound in the receiving room and to the transmission from the source to the receiver room.

The measured response in the classical method based on noise excitation may in theory be described as a convolution between the excitation signal and the impulse response of the room. However, in the classical method with noise excitation the response is recorded directly and information about the impulse response is normally not known.

According to the new methods, described in this standard, the results may be obtained from processing of the impulse response itself.

NOTE 2 The impulse response is normally the combined impulse response of the system consisting of amplifiers, transducers, applied filters, and the enclosure between the transmitting and the receiving points.

Several methods may be applied to obtain the impulse response or the frequency response function, which is linked to the impulse response by Fourier transformation. All such methods may be used if they are able to demonstrate reliable results within normal measurement conditions.

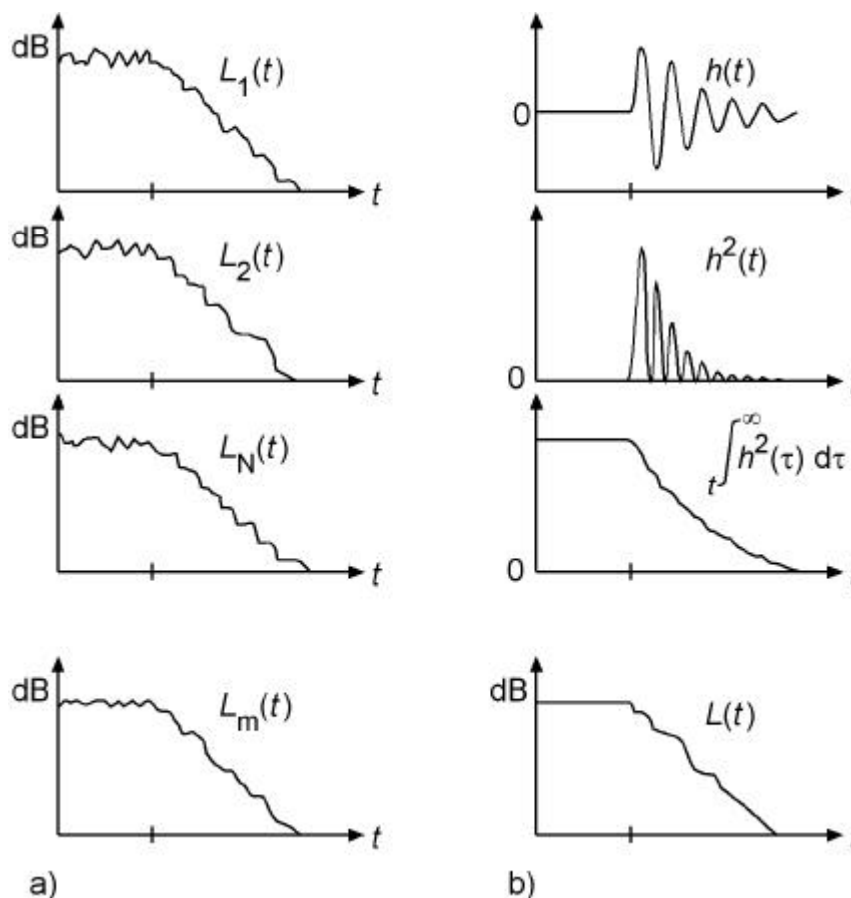

Key

- a) classical method
- b) new method

NOTE In the classical method a) an approximation, $L_m(t)$, to the expected decay is found by averaging (ensemble) a number of individual decays, $L_1(t)$, $L_2(t)$, ... $L_N(t)$, based on noise excitation. By application of the new method b) the expected decay, $L(t)$, is found by processing the impulse response $h(t)$.

Figure 2 — Illustration of the difference between classical and new method

When a room has been excited by stationary white noise for a time sufficient to obtain stationary conditions and the noise is thereafter switched off at the time $t = 0$, the expected level at any time $t > 0$ will be [1]:

$$L(t) = 10 \times \lg \left[\frac{N_0}{C_{\text{ref}}} \int_t^{\infty} h^2(t) dt \right] \text{ dB} \tag{1}$$

where

- N_0 is a constant specifying the signal power per unit bandwidth of the excitation signal;
- $h(t)$ is the impulse response; and
- C_{ref} is an arbitrary selected reference value for the level calculation.

The decay corresponds to the expected decay based on the classical method, which conventionally is approximated by a straight line.

NOTE 3 Due to the fact that the running time, t , is the lower start point for the integration, the operation of the formula can be described as backward integration. In an alternative form of formula (1), the integral starts at ∞ and runs backward to the actual time. Historically, this was achieved using analogue technology by playing a tape with the recorded response in the reversed direction.

The formula (1) does not consider the extraneous noise normally accompanying a measurement.

When a fractional-octave-band filter is a part of the measured system, formula (1) will describe the expected decay according to the classical method for the applied filter band.

Formula (1) may be used to compute the expected level at any time after the signal source was switched off. The formula may also be used to obtain the expected mean level before the excitation was switched off, L_0 . The level may be obtained from formula (1) by setting $t = 0$.

$$L_0 = 10 \times \lg \left[\frac{N_0}{C_{\text{ref}}} \int_0^{\infty} h^2(t) dt \right] \text{ dB} \quad (2)$$

4.3 Sound transmission between two rooms

If a noise source is placed in a source room and the sound level is measured at a point S, the expected level, L_S , may according to formula (2) be obtained from the impulse response between the excitation point and the point S: $h_S(t)$.

$$L_S = 10 \times \lg \left[\frac{N_0}{C_{\text{ref}}} \int_0^{\infty} h_S^2(t) dt \right] \text{ dB} \quad (3)$$

In a similar way, if the sound level is measured in an adjacent receiving room at a point R, the expected level, L_R , may be obtained from the impulse response between the excitation point and the point R: $h_R(t)$.

$$L_R = 10 \times \lg \left[\frac{N_0}{C_{\text{ref}}} \int_0^{\infty} h_R^2(t) dt \right] \text{ dB} \quad (4)$$

The expected sound level difference between the source and the receiver room D , may therefore be computed as:

$$D = L_S - L_R = 10 \times \lg \left[\frac{\int_0^{\infty} h_S^2(t) dt}{\int_0^{\infty} h_R^2(t) dt} \right] \text{ dB} \quad (5)$$

The variable describing the excitation power, N_0 , is eliminated in the result for the level difference as the arbitrary chosen reference C_{ref} .

NOTE The new methods specified in this standard may also be applied to the measurement of sound insulation of facades. In this context one of the measurement positions will be an outdoor position.

4.4 Using the frequency response function

A sinusoidal signal has a unique position in the theory of signals and linear time invariant systems. If the transients formed when signals are switched on and off are disregarded, the response for such a system to a

sinusoidal excitation will always be sinusoidal with the same frequency. The amplitude (gain) and the phase may however change. Information about the change of amplitude and phase between input and output as a function of frequency is called the frequency response function of the system. The frequency response function will, as the impulse response, give full information about the response to any input signal. The frequency response function may be obtained from the impulse response by Fourier transformation.

Formula (2) may be transformed by the application of Parseval's theorem:

$$N_0 \int_0^{\infty} h^2(\mathbf{t}) d\mathbf{t} = \frac{N_0}{2p} \int_{-\infty}^{\infty} |H(\mathbf{w})|^2 d\mathbf{w} \tag{6}$$

where

\mathbf{w} is the angular frequency; and

$H(\mathbf{w})$ is the frequency response function obtained by the Fourier transformation of the impulse response $h(t)$:

$$H(\mathbf{w}) = \mathbf{F} \{h(t)\} = \int_{-\infty}^{\infty} h(t) e^{-j\mathbf{w}t} dt \tag{7}$$

where

$$j = \sqrt{-1}$$

NOTE In formula (6) it is assumed that $h(t) = 0$ for $t < 0$, which will be the case for a physical, causal system.

Formula (6) shows that only the modulus of the frequency response function may be used for the level calculation. This is in contrast to the measurement of reverberation time where both the phase and modulus of the frequency response function is required.

By combining formulas (5) and (6), the expected sound level difference between the source and the receiver room D , can be computed from the frequency response functions for the source room and the receiving room, respectively:

$$D = L_S - L_R = 10 \times \lg \left[\frac{\int_{-\infty}^{\infty} |H_S(\mathbf{w})|^2 d\mathbf{w}}{\int_{-\infty}^{\infty} |H_R(\mathbf{w})|^2 d\mathbf{w}} \right] \text{ dB} \tag{8}$$

5 Measurement of the impulse response

5.1 General

The impulse response for a room will typically be a signal with a large number of periods. The envelope of the signal will be irregular but typically have a fast attack-time and an exponential decay.

The impulse response may be measured as the response of the room to a very short acoustic pulse. However, it will in most cases where sources other than a loudspeaker are used, be difficult to have sufficient control of the spectral content and the directional characteristics of the excitation.

To obtain the required control of the excitation signal, the impulse response is in most practical cases obtained by digital signal processing. The room is excited by a known signal for a certain time and the impulse response is calculated from the response to the excitation. The excitation signal is distributed over a longer

period of time to increase the total radiated energy. This procedure will enhance the achievable dynamic range and reduce the influence of extraneous noise.

Several methods for the measurement of the impulse response are described in the literature, see [1] to [3], [8] to [10]. Most of the methods involve deconvolution techniques to obtain the impulse response.

For measurements of the impulse response, movement of the source or the microphones are not acceptable as it will violate the requirement to time invariance. The impulse response of a room is formed by a complex interaction of sound waves reflected between the floor, ceiling and walls of the room. Between the reflections, the air in the room influences the transmission. Movement of the air or change in the speed of sound (temperature) may also violate the requirement for time-invariance.

5.2 Excitation signal

5.2.1 General

In the classical methods, random noise or an impulse with a bandwidth at least equal to the bandwidth of the measurement channel is required. The random nature of the noise will give a stochastic distribution of the measured levels and limit the repeatability of the measurement. The new methods apply deterministic excitation signals, i.e. they can be accurately reproduced, and thereby enhance the repeatability of the measurement.

5.2.2 Spectral requirements

5.2.2.1 General

The effective frequency range of the excitation signal shall at least cover the actual fractional-octave-band being measured. If a broad-band measurement covering the whole audio range is being performed, the aim is to approximate the spectrum of the excitation signal, as captured at the receiver position, to that of the ambient noise prevailing there. Doing so, a frequency-independent signal-to-noise ratio will be obtained. The typical sources of background noise (air conditioning, traffic, etc) tend to have a spectral distribution, which increases with decreasing frequency. For this reason, the excitation signal should feature an emphasis at lower frequencies when room impulse responses are to be measured.

In many of these cases, a pink excitation signal (with constant energy per fractional-octave-band) is suitable to obtain a sufficient signal-to-noise ratio.

In sound insulation measurements, however, the sound reduction index normally increases at higher frequencies, making it necessary to increase the energy of the excitation signal in this range.

The most sophisticated emphasis scheme would involve compensating the acoustical power response of the measurement loudspeaker and adapting to the spectral distribution of the background noise. A smoothed version of the latter, multiplied by the inverted speaker response, confined to the intended frequency range, can be used as template for the generation of a suitable excitation spectrum.

5.2.2.2 Repetitive excitation

If a repetitive excitation signal is used, the spectrum of the excitation will consist of narrow spectral lines where the distance between adjacent lines, Δf , will be given as the inverse of the time for one repetition period T_{REP} :

$$\Delta f = \frac{1}{T_{\text{REP}}} \quad (9)$$

In order to ensure that all modes of the room are excited, the repetition period shall not be shorter than the reverberation time, T , for the room being measured. This requirement applies to the measurement of reverberation time as well as level differences.

$$T_{\text{REP}} \geq T \quad (10)$$

NOTE Each room-mode may be approximated by a second order band-pass function with a certain quality-factor (Q-factor). Larger Q-factor means narrower frequency response and a longer decay after excitation has ceased. For a second order function with bandwidth (-3 dB) B in hertz, the virtual reverberation time will be approximately $(2,2/B)$. The requirement for the repetition time ensures that at least two spectral lines of excitation falls within the bandwidth of any room-mode.

5.2.2.3 Non-repetitive excitation

A non-repetitive excitation signal may be of any suitable length. However, the excitation shall be succeeded with a period of silence in order to allow the decaying response to be properly recorded. The decay shall be recorded over a period equal to at least half of the reverberation time. For a sweep excitation from a low to a high frequency as described in Annex B, the required length of the period of silence will normally be determined by the reverberation time for the higher frequencies.

5.2.3 Level and linearity

The sound power in the excitation shall be sufficiently high to obtain an effective signal-to-noise ratio satisfying the requirements in the International Standard specifying the applicable classical method.

Methods involving deterministic excitation signals are generally more efficient at suppressing extraneous noise than the classical method. Enhancement of the signal-to-noise ratio by 20 dB to 30 dB or more compared to the classical method may be obtainable.

The use of loudspeakers typically introduces non-linear distortion in the system. Distortion violates the requirement for linearity in this method. Distortion due to the loudspeaker increases with the excitation level. The user should be aware of the problem and experiment with the excitation level to obtain the optimum signal-to-noise ratio. Sometimes the signal-to-noise ratio can increase by reducing the excitation level. This needs special consideration with the MLS method as described in Annex A. When properly established, the swept sine method described in Annex B allows elimination of artefacts in the measurement result caused by harmonic distortion.

The region where the impulse response decays into the noise floor will usually be the most affected by non-linearities. This makes the measurement of reverberation more vulnerable to the effect of distortion than the measurement of level differences.

5.2.4 Directivity

The directivity for the source shall comply with the requirements in the referred classical method.

5.2.5 Number of source positions

The number of source positions shall comply with the requirements in the referred classical method.

5.3 Measurement of the response

5.3.1 Transducers for measurement

Transducers for the measurement, normally measurement microphones, shall comply with the requirements in the referred classical method.

5.3.2 Frequency weighting

The methods in Annex A and B describe the measurement of broadband impulse responses. The broadband impulse responses shall be further processed to obtain fractional-octave-band weighted impulse response for the required range of frequency bands.

Although formulas (1) to (5) are general, the impulse responses in these formulas shall be fractional-octave-band weighted in order to produce results valid for fractional-octave-bands.

In principle, the fractional-octave-band weighted impulse response is obtained as the output from a fractional-octave-band filter, as specified in IEC 61260, to the response of the broadband impulse response.

When selecting methods to perform the requested frequency weighting, precautions shall be taken to ensure that the tolerances for the frequency weighting are within the requirements stated in IEC 61260 for the appropriate class of filters as specified in the classical method. Sampling frequency shall be selected and precautions against effects from frequency aliasing shall be taken accordingly.

For excitation with repetitive signals, the response is recorded with the time and frequency resolution set by the requirements to the excitation signal and with a length equal to one or more period of the excitation signal.

For non-repetitive excitation and measurement of level, the recorded part of the response shall cover the time from the start of excitation to the time where the response in each fractional octave band is decayed by more than 30 dB. For the measurement of reverberation time with non-repetitive excitation, the record shall at least cover the part of the decay required in the referred classical standard.

5.3.3 Level linearity and dynamic range

The signal processing shall have sufficient resolution and dynamic range to comply with the requirements for level linearity as specified in IEC 61672-1.

Measurement equipments made for obtaining the result by the new method can normally not be tested as conventional sound measuring equipment. In general the microphone signal is digitised and the result is obtained by digital processing on the samples representing the microphone signal. Proper operation of the microphone and digitising circuitry can often be verified by conventional testing, but not the entire calculation process. The accuracy of the digital processing are regarded to be determined by the design of the equipment and not to be affected by ageing or changes in the environmental conditions of operation as long as valid results are presented.

It is recommended to validate the design and operation of the system by making measurements where the results can be compared to results obtained by the classical method. Measurements at fixed positions in rooms where the acoustical conditions are well controlled may be used. However, a time invariant system with electrical input- and output signals may be more convenient. Such a system may be a digital reverberator without time modulation. The validation should be performed with the normal span of reverberation times. The performance of the measuring equipment in reduced signal-to-noise ratios may be investigated by adding broadband random noise to the analogue input- or output signals.

It is recommended to test the microphone and digitising circuitry as well as the excitation generator at regular intervals, as appropriate (periodic verification).

5.3.4 Crosstalk

The application of deconvolution measurement techniques allows measurements with large dynamic ranges often including levels, which extend below the level of extraneous noise. Even levels below the inherent noise levels in microphones and measurement system may be measured. Care shall therefore be taken to eliminate influence from unwanted signal paths such as electrical crosstalk. Cables for the excitation, such as loudspeaker cables, should be located far away and screened from microphone cables. Even internal crosstalk in the instrumentation, normally buried in the self-noise, can show up.

Sufficient immunity from crosstalk can be demonstrated by substituting the normal transducer (microphone) with a dummy-device having very low sensitivity to the signal to be measured.

A display of the impulse response, if available, may indicate a possible crosstalk problem. Sound signals are normally delayed, even the direct sound, due to the speed of sound and distance between the source and the receiver. Crosstalk signals, being electrical signals, are normally not delayed. To exclude the influence of any residual crosstalk, windowing may be applied at the beginning of the impulse response to attenuate any non-acoustical components.

5.3.5 Limits for the time integration

5.3.5.1 Measurement of level

Formula (2) specifies an infinitely long integration period. This is neither possible nor wanted. The length of the recorded impulse response will give the maximum value for the upper integration limit.

Measured impulse responses will always be accompanied by unwanted noise from extraneous sources and from self-noise in the instruments. Effects from violation of the requirement to linearity and time-invariance may add to the noise. The contribution from the noise in the integral will increase with an increasing length of the integration interval. If the integration is performed between 0 and t_1 , the level will be given by:

$$L = 10 \times \lg \left\{ \frac{1}{C_{\text{ref}}} \left[N_0 \int_0^{t_1} h^2(t) dt + \int_0^{t_1} e^2(t) dt \right] \right\} \text{ dB} \quad (11)$$

where

$e(t)$ is the background noise signal.

It is assumed that there is no correlation between $h(t)$ and $e(t)$.

Too low a value for the upper integration limit will give too low a value for the integral. Figure 3 shows a sketch how the value of t_1 affects the calculated level.

Although the reverberation time may not be known, the upper integration limit t_1 in formula (11) for a level measurement shall be selected from a rough estimate of the reverberation time T for the appropriate fractional-octave-band in question:

$$t_1 \geq T/3 \quad (12)$$

This implies that the integration should at least be made until the -20 dB point on the squared impulse response curve. The optimum value of t_1 will depend on the signal-to-noise ratio. If the background noise is low, higher accuracy is obtained by increasing the integration interval. The demand is to obtain an effective signal-to-noise ratio exceeding or equal to the required signal-to-noise ratio in the classical method.

Classical methods referred to in this International Standard describe procedures to correct measured levels when the signal-to-noise ratio is low. The new measurement methods may be used to measure the effective signal-to-noise ratio and thus compensate for influence from the noise automatically and as a part of the method. If the noise compensation is a part of the method, no further noise compensations shall be applied, even if stated in the description of the classical method.

The integration limit may be selected individually for each fractional-octave-band or as a common limit based on the highest value of T .

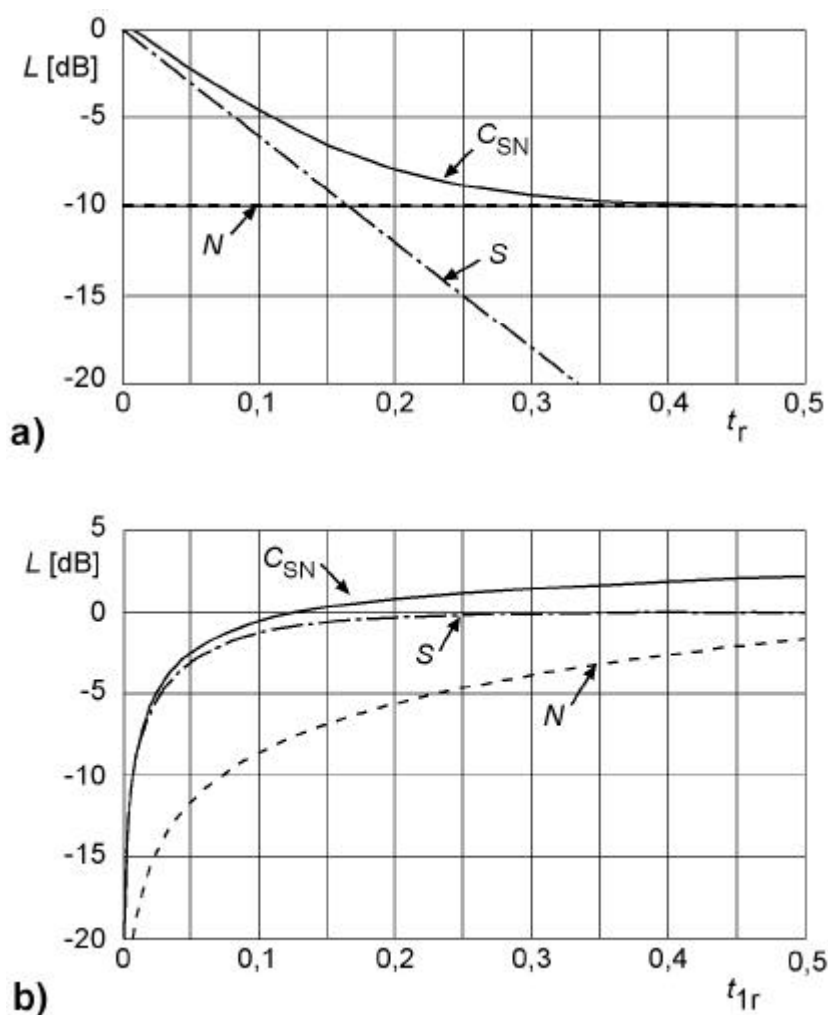

Key

S	signal from impulse response
N	noise
C _{SN}	signal from combined impulse response and noise
t_r	time relative to reverberation time
t_{1r}	time for integration limit relative to reverberation time

a) Sketch of the envelop of the impulse response, the background noise and the combination of impulse response and noise.

Note 1 The effective signal-to-noise ratio is only 10 dB in this example in order to display the contribution from the background noise. Time is relative to the reverberation time.

b) Sketch of the calculated levels as a function of the upper integration limit t_{1r} .

Note 2 Time is relative to the reverberation time. The levels are as calculated according to formula (11). The figure shows the first part, the second part and the complete integral. 0 dB indicates the correct level corresponding to an infinite integration period without any noise contribution. Note that the difference between the noise and the maximum envelope of the impulse response is only 10 dB in this example.

Figure 3 — Integration limits

Formula (11) shall be used for the calculation of level difference as defined by formula (5). The integration limit, t_1 , from formula (12) may be selected independently for the two rooms or the highest value may be used.

5.3.5.2 Measurement of reverberation

As for level measurements, the upper limit for the time integral in formula (1) shall be limited in order to reduce the contribution from unwanted noise.

$$L(t) = 10 \times \lg \left\{ \frac{1}{C_{\text{ref}}} \left[N_0 \int_t^{t_2} h^2(t) dt + \int_t^{t_2} e^2(t) dt \right] \right\} \text{ dB} \quad (13)$$

It is recommended to set t_2 to be the time where the envelope of the exponential decay in the impulse response $h^2(t)$ intersects with the tail of the measured response determined by the extraneous background noise. Different methods are described in the literature to compensate for the noise and the truncation of the integration interval (see [5]).

5.3.6 Response averaging

Averaging more impulse responses before the final impulse response is further processed can enhance the effective signal-to-noise ratio. The impulse response for a room will ideally be determined by a deterministic process and give a repeatable signal. The extraneous noise, however, will typically be a stochastic signal uncorrelated with the impulse response. The effective signal-to-noise ratio will then increase by 3 dB for each doubling in the number of measurements in the averaged response.

Violation in the requirements for time invariance and non-linearity will reduce the enhancement of the effective signal-to-noise ratio and will set a limit for the achievable effective signal-to-noise ratio.

5.3.7 Number of measurement points and spatial averaging

The number of measurement points (combinations of source/microphone positions) shall comply with the requirement in the referred classical method.

The combination of levels or level differences shall comply with the requirements in the referred classical method. If it is required that the spatial averaged level differences shall be obtained by first making the average of levels in each room, a similar procedure shall be followed.

5.3.8 Stability and time-invariance

All parts of the signal chain, from the excitation to the received signal, have to be time-invariant. This is particularly important with the MLS method described in Annex A, whereas the swept-sine method described in Annex B, is more robust to such variations. The need for time-invariance yields the gain (amplitude) and particularly the phase stability. Normally, electronic components used in analogue and digital signal processing are sufficiently stable and seldom need consideration. The loudspeaker sensitivity changes when the voice-coil heats up, thus previous use may influence the measurement results when the signal has been fed with substantial power. The user should therefore aim at stationary, repeatable conditions.

The source or the measurement microphones shall not be moved during a measurement. If a loudspeaker is used for facade measurements, the loudspeaker shall be firmly mounted and shall not be allowed to swing or rotate.

Higher frequencies are more likely to be affected by time-variance than lower frequencies.

The measurement methods based on recovering impulse responses are in general more sensitive to movements of persons in the measurement rooms than the classical method.

The last part of an impulse response is likely to be more affected by time-variance than the initial part. This makes the measurement of reverberation times more vulnerable than the measurement of level differences. Time variance in the system will typically increase the decay rate for the final part of the decay and decrease the measured reverberation time.

5.3.9 Environmental conditions

The new measurement methods may be applied within the environmental conditions for the classical method. However, due to an enhanced sensitivity to changes in the environmental conditions during a measurement, great care shall be taken to keep the conditions stable and within the limits for the various methods described in the annexes.

The sound transmission in the air is highly sensitive to changes of the environmental conditions. Such transmission forms a part of the system when airborne sound transmission is measured.

Time variances due to changes in the environmental conditions are mainly caused by temperature variations and changes in wind speed. Measurements taking a longer period of time to perform will normally be more sensitive to a drift in the temperature than a faster measurement. If more periods of the response are synchronously averaged, the requirement for constant environmental conditions applies for the total measurement period.

Information on the sensitivities for the methods described in Annex A and Annex B are given in the annexes. However, if more impulse responses measured according to Annex B is averaged, the restricted limits for environmental conditions as described in Annex A should be followed.

5.3.10 Calibration and check of accuracy

5.3.10.1 General

The referred classical methods normally require that the measuring equipment be checked by using a sound calibrator before and after a sequence of measurements. In case the equipment cannot be tested by the normal use of a sound calibrator, the following procedure shall be used to ensure proper operation when the measurement is based on omni-directional working standard microphones or microphones of similar operation:

NOTE 1: Types of microphones other than omni-directional – like figure of eight microphones, cannot be calibrated by a sound calibrator.

NOTE 2: The results obtained by the new method are normally not dependent of the absolute sensitivity of the channels since the measured quantities are either level differences or rates of level change (reverberation time).

5.3.10.2 Calibration of equipment with one measurement channel

A level measurement with the microphone placed close to the excitation source shall be performed. The effective signal-to-noise ratio shall be at least 30 dB. The measurement shall be repeated under identical conditions and the obtained level differences, for all relevant fractional-octave bands, shall be within the required measurement accuracy.

5.3.10.3 Calibration of equipment with two or more measurement channels

One channel shall be designated reference channel. For each of the other channels, the response for the channel shall be compared to the response of the reference channel. The microphone for the channel to be compared shall be placed face-to-face to the microphone of the reference channel. The distance between the microphones shall be within 1/10 of the wavelength corresponding to the centre frequency of the highest relevant fractional-octave band.

The level difference shall be measurements with the microphones placed close to the excitation source. The effective signal-to-noise ratios shall be at least 30 dB. The obtained level differences shall, for each of the pairs, be within the required measurement accuracy for all relevant fractional-octave bands.

NOTE It is recommended to use microphones of similar design (size, frequency response, directional response, etc.) Some microphones may have protection grids with sound ports that may be blocked if the microphones are placed too close to each other.

6 Measurement of the frequency response function

The frequency response function may be obtained from the impulse response by Fourier transformation. It may also be measured as the response to sinusoidal excitation in the required frequency range and the response recorded as amplitude and phase.

As shown in formula (6), the phase information is not needed for level measurements. If suitable detection methods are used, the requirements to time-invariance may be relaxed compared to the direct measurement of the impulse response.

The frequency may be changed continuously, normally from below the lowest band-edge frequency of the lowest fractional-octave-band to be measured to above the upper band-edge frequency of the upper band. A frequency sweep where the frequency increases exponentially as a function of time mimics a pink noise source in the classical method. The integral over the frequency in formula (6) may then be substituted by an integral over the time for the sweep.

Narrow band tracking filters in the measurement channel may be used to reduce the noise and remove harmonic components caused by non-linearity in the measuring system. The bandwidth of the filters shall be sufficient wide to prevent modification of the decay-rate due to the reverberation.

7 Precision

Where the environmental conditions can be controlled to be within the requirements stated in Annex A or Annex B as appropriate, the new methods specified in this International Standard, are considered to have similar or better precision than the referred conventional method.

8 Test report

The expression of results and the information in the test report shall comply with the referred classical method. Additionally, the test report shall contain at least the following information:

- a) Reference to this International Standard;
- b) short description of the applied method: signal type, signal duration, number of averages etc.;
- c) number and title of the International Standard of the referred classical method.

Annex A (normative)

Maximum Length Sequence Method

A.1 General

This Annex gives only a brief introduction to the measurement method based on Maximum Length Sequences (MLS) and the Hadamard transformation. Extensive information about the method and applications in the field of building acoustic is available in the literature (see [5] to [7] and [10]).

A Maximum Length Sequence is a binary sequence. When used for excitation, the binary values are output at a fixed rate, f_c , which for this description is assumed to be equal to the sampling frequency for the recorded response. Although the sequence is deterministic, it sounds like white noise and each of the binary values appears in a random-like manner.

The MLS is characterised by an order N given by a whole number. The length of the sequence is $l_1 = 2^N - 1$. The autocorrelation of the sequence will almost be a periodic delta-pulse when the sequence is replayed periodically. The signal will thus be an approximation to a record of white noise replayed with a repetition frequency f_{REP} :

$$f_{\text{REP}} = \frac{1}{T_{\text{REP}}} = \frac{f_c}{2^N - 1} \quad (\text{A.1})$$

For this description, it is assumed that the sequence is replayed periodically. The measured impulse response will therefore also be periodic, this mean that the tail of the response outside the record will be folded back to the beginning of the record [11].

When using white excitation signals, the impulse response of any linear system may in general be obtained from the amplitude ratio and the cross correlation between the output and the input. When the input is a periodic Maximum Length Sequence, using the Hadamard transform may speed this cross correlation process up. The process is illustrated in Figure A.1.

The Hadamard transform may be done very efficiently as a Fast Hadamard Transform (FHT) and consists of combining different samples in the recorded response by additions and subtractions. Included in the method is the addition of one extra sample in the record so the length of the output sequence, l_2 , is a power of two values:

$$l_2 = l_1 + 1 = 2^N \quad (\text{A.2})$$

The output from the Hadamard transform will be the impulse response for the measured system. The system is then defined with the electrical excitation as *input* and the input to the recording device as *output*. Therefore, in addition to the room response, the power amplifier, loudspeaker and eventually filtering networks will be a part of the system. For most building acoustic measurements as described in this standard the main characteristics in the response will be determined by the room. The impulse response shall be further processed to obtain the fractional-octave-band filtered response.

Due to the periodic nature of the excitation, the measured impulse response will also be periodic. If the impulse response is longer than one period, the tail of the impulse response will add to the first part (time aliasing – circular convolution).

A.2 Sequence length

The length of the sequence shall be equal or longer than the reverberation time as required in formula (10).

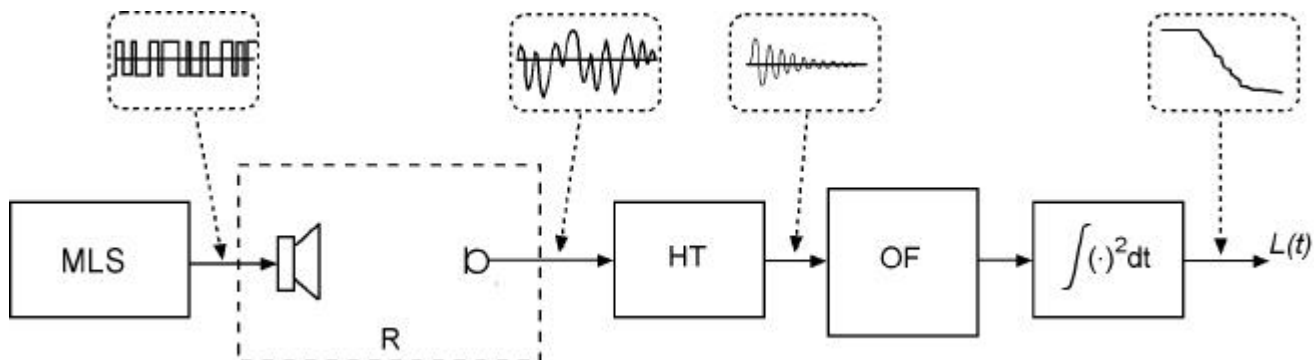

Key

- MLS generator for MLS-signal
- R room
- HT Hadamard transformation
- OT fractional-octave filter.

Figure A.1 — Scheme for MLS process

The lower limit for the clock frequency, f_c , which normally is equal to the sampling frequency for the recorded response will be set by the required upper frequency range. The length of the sequence and the clock frequency will set the lower limit for the order of the MLS.

NOTE The calculation of the required order can be illustrated by the following example: The estimated reverberation time, $T = 1,5$ s, upper measurement frequency is 3,55 kHz (upper band-edge frequency for 3,15 kHz filter band) clock and sampling frequency is 12 kHz. The lower limit for the order is given by:

$$T_{\text{REP}} = \frac{2^N - 1}{f_c} \geq T \tag{A.3}$$

This corresponds to

$$N \geq \frac{\lg(T f_c + 1)}{\lg(2)} = \frac{\lg(1,5 \times 12000 + 1)}{\lg(2)} \approx 14,2 \tag{A.4}$$

The smallest whole number satisfying this requirement is $N = 15$. The order may, however be reduced to 14 if the sampling frequency is reduced closer to the limit 2 x 3,55 kHz or 7,1 kHz.

A.3 Signal-to-noise ratio

A.3.1 General

If more periods of the recorded response or the impulse response are synchronously averaged, the effective signal-to-noise ratio may be enhanced as described in 5.3.6. In addition, if the important part of the impulse response is shorter than the length of the measured response, the sequence used for computing the values may be truncated and thereby the noise in the rest of the record will be removed. This is based on the fact that

normal uncorrelated noise will still have a constant distribution along the time-axis after the Hadamard transformation. Even an extraneous impulse signal will have a stationary distribution along the time-axis after the Hadamard transformation.

The formulas below for signal-to-noise ratios assume stable environmental conditions and linearity so the system can be regarded as a linear time-invariant system.

A.3.2 Level measurements

Most of the energy of the impulse response will reside in the first part as described in 5.3.5. If the integration limit is selected according to formula (11), the enhancement in the effective signal-to-noise ratio in dB, Δ , compared to the classical method will be approximately given by (see [5]):

$$\Delta \approx 10 \times \lg \left\{ \frac{n T_{\text{REP}}}{t_1} \right\} \text{ dB} \quad (\text{A.5})$$

where

n is the number of averages.

The signal-to-noise ratio for the classical method is the ratio obtained when the MLS-signal is used as a conventional excitation signal.

A.3.3 Measurement of reverberation time

The MLS sequence can be regarded as a conventional noise excitation signal and the reverberation time calculated by the classical interrupted noise method. If the signal-to-noise ratio in this measurement is used as a reference, the enhancement, Δ , in the effective signal-to-noise ratio for the MLS/Hadamard method will be approximately given by (see [5]):

$$\Delta \approx 10 \times \lg \left\{ \frac{13,8 \times n T_{\text{REP}}}{T} \right\} \text{ dB} \quad (\text{A.6})$$

The level range used to obtain the reverberation time by the new method shall comply with the referred classical method.

A.4 Time invariance

A.4.1 General

Time variance in the system to be measured can limit the achieved effective signal-to-noise ratio and leads to unreliable results. Besides linearity, time invariance is a critical parameter in the application of MLS based methods and shall always be regarded. Slow time variances due to environmental conditions are described in 5.2.4.

A.4.2 Movement

All excitation sources, reflectors, microphones, other equipment or room boundaries shall be stationary and shall not be moved during a measurement.

A.4.3 Environmental conditions

A.4.3.1 Temperature

The following limits found in the literature can be used as a guide (see [5] to [7]):

Maximum temperature change, DJ , during a measurement of level difference:

$$DJ \leq \frac{1300^{\circ}\text{C}}{f T} \quad (\text{A.7})$$

where

f is the centre frequency of the fractional-octave-band filter; and

T is the reverberation time.

For the measurement of reverberation time in the range 0 dB to 30 dB below the stationary level, the following limit for the change in temperature is given:

$$\Delta J \leq \frac{200^{\circ}\text{C}}{f T} \quad (\text{A.8})$$

A.4.3.2 Maximum wind speed (outdoor measurements)

Measurements shall only be performed when the average wind velocity is less than 4 m/s and the wind velocity during gusts is less than 10 m/s. In the case of wind, the wind velocity close to the loudspeaker shall be monitored to ensure that this requirement is fulfilled. The wind measurement equipment shall have an accuracy of at least 10%, and a time constant of no more than 2 seconds.[6]

A.4.4 Distortion

Distortion in the excitation channel will normally show up as an increased noise floor including spikes. The excitation channel shall therefore be operated in a range where response is mainly linear. When using MLS-method an increased effective signal-to-noise ratio may be obtained by reducing the excitation amplitude. [7] gives further guidelines.

Some sources of nonlinearity may generate non- or sub-harmonic distortions (e. g. rattling) and should also be kept at a low level.

Annex B (normative)

Swept-Sine Method

B.1 General

Generally speaking, any kind of excitation signal can be used to determine the impulse response and respective frequency response function of any linear and time-invariant system, provided that it contains enough energy at every frequency of interest. The impulse response can be obtained from the response to the excitation by deconvolution, or the frequency response function can be obtained by dividing the output spectrum of the system under test by the spectrum of the input. The last implies Fourier-transformation of the input- and output-signal in order to perform the division in the spectral domain.

Using sinusoidal sweeps as the excitation signals offers a couple of advantages compared to the method described in Annex A. The obtainable advantages include reduced sensitivity to time variance (temperature and air movement) and elimination of the deterioration of the effective signal-to-noise ratio due to harmonic distortion. As all harmonic distortion may be deleted from the results, the sinusoidal excitation signal can be fed with substantially more power than MLS-signals. At quiet sites, sweep measurements can provide signal-to-noise ratios in excess of 100 dB.

Measurements with sweeps are less vulnerable to the deleterious effects of time variance. In outdoor measurements, these frequently occur due to air movement. Under windy weather conditions, sweeps are sometimes the only viable option when measuring impulse responses over long distances.

A sweep excitation may be made once, from the lower to the higher frequency, or repeated in a periodic manner. This analysis is based on one single sweep. If convenient, the total frequency range may be divided in blocks covering only a part of the range, e.g. each octave may be measured with a separate sweep.

Effects of using periodic sweeps or repeated sweeps are covered in B.8.

When a sweep is emitted only once, all its energy is being used for evaluating the frequency response function. This aperiodic use of the excitation signal reduces the measurement time, though a gap of silence has to follow the sweep to allow collecting all delayed components.

NOTE A number of different names have been used in the literature to describe the swept-sine method. This includes "chirp", "sinusoidal sweep" and "time-stretched pulse".

B.2 Sweep duration

In contrast to measurements with periodic excitation signals, there are no special requirements relating the sweep duration to the expected reverberation time that shall be considered. Anything from short chirps to sweeps many times longer than the reverberation time may be used. However, the acquisition time for recording the sweep response shall be longer than the sweep itself to collect the reverberation until it has decayed under the noise floor.

In room and building acoustics, the reverberation time is normally longest for the lower frequencies. When very long sweeps (many seconds) are being used, the final gap only has to accommodate the reverberation at the highest frequencies, which generally is quite short. This holds because all the lower frequency components arrive while the excitation signal is still sweeping upwards.

Increasing the sweep duration brings more acoustic energy into the room to be measured and thus increases the effective signal-to-noise ratio. Generally a prolonged sweep should be preferred over averaging as it reduces the vulnerability to time variance and eases the separation of the distortion products.

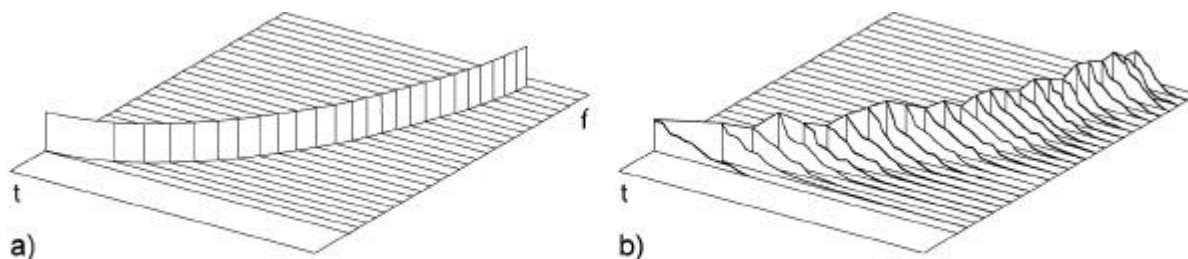

Key

- t time
- f frequency
- a) Excitation
- b) Response

Figure B.1 — Time-frequency diagram for exponential sweep

B.3 Sweep Generation

B.3.1 General

According to the spectral requirements mentioned in 5.2.2, a non-white excitation spectrum is preferable in the majority of measurement tasks. The spectral contents may be modified by the change of the amplitude as well as the instantaneous sweep speed. In most cases, it is advantageous to keep the amplitude at a constant value and let the sweep speed be changed with the frequency. The sweep is started at or below the lowest band-edge frequency of the lowest fractional-octave-band to be measured and continues upwards to at least the upper band-edge frequency of the highest fractional-octave-band to be measured. An extension of the sweep with a quiet period is normally required and belongs to the excitation signal.

In cases with moderate background noise, it is normally a safe practice to use sweeps with a length of 2 times to 4 times the longest reverberation time and leave a silent gap equalling the expected longest reverberation time.

B.3.2 Sweeps with white and pink spectrum

A linear sweep with constant amplitude corresponds to equal energy per hertz and is normally designated a white spectrum. If the frequency increases exponentially with the time, the time to sweep each octave is constant. The energy per fractional-octave-band will therefore be constant and the sweep mimics a pink spectrum. An exponential sweep is the normal excitation signal corresponding to pink noise in the referred classical methods.

B.3.3 Synthesis of sweeps with arbitrary amplitude spectrum

The spectrum of the excitation signal may be adjusted to the requirements as described in 5.2.2 by change of the sweep rate. Generally, adjustment of the sweep rate is preferred compared to change of the envelope (amplitude) as it allows maintaining a constant distance to the clipping level of an amplifier.

If the sweep rate at a particular frequency is lowered, more energy will be concentrated in this part of the spectrum. By properly controlling the sweep rate, sweeps with almost arbitrary amplitude spectrum, yet almost constant temporal amplitude envelope can be synthesized. [8] gives further details of how to obtain a wanted spectrum. The article also describes methods to reduce transient from the start and stop of the sweep.

B.4 Recording the response

The response to the sweep excitation has to be recorded from the start of the sweep to a time where the sound delayed by the reverberation is received. Prolonging the time for the record may aim to the reduction of interference from harmonic distortion components. The time needed depends on the sweep speed, the frequency range to be covered and the reverberation of the room(s). For the measurement of level differences, the recorded decay shall cover at least 30 dB or half the reverberation times. For measurement of reverberation time, the decay shall cover the range specified in the referred classical standard.

The needed length of the recording depends on the application. For level measurements, only the upper 30 dB of the decay influences the level significantly. For measurement of reverberation time, a higher dynamic range is needed which leads to the need for longer length of the record in order to reduce the contamination from harmonic distortion.

Figure B.1 shows a time–frequency plot of an exponential sweep excitation and the corresponding response. Note that the received frequency components are delayed due to the reverberation.

B.5 Deconvolution

The process of deconvolution to obtain the impulse response of the room is illustrated in Figure B.2 and Figure B.3 as two alternative procedures. The complex frequency response function can be obtained by direct deconvolution or by spectral division between the spectrum of the response and the spectrum of the excitation.

In Figure B.2, the deconvolution is done by convolving the received signal with a signal being the inverse of the excitation signal. The inverse signal is the signal with the property that convolving it with the excitation signal, an ideal impulse is created. The broadband impulse response is further processed to obtain the $L(t)$ function as defined in formula (1) for each fractional-octave-band. Figure B.2 is only meant for illustrating the process of signal processing. For example, the filtering to obtain fractional-octave-band responses may be done in the frequency domain as long as the requirements in 5.3.2 are satisfied.

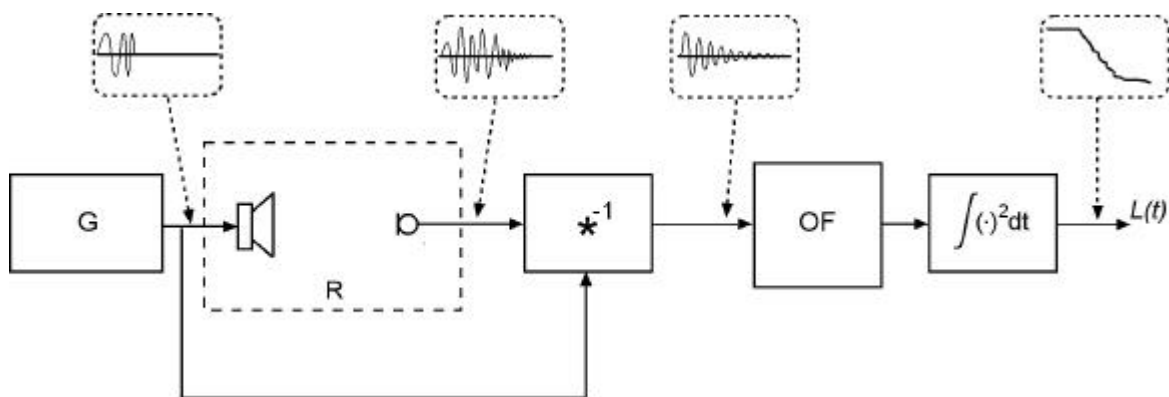

Key

- G sweep generator
- R room
- *⁻¹ de-convolution
- OF fractional-octave filter

Figure B.2 — Direct deconvolution

In Figure B.3, the transformation between the time- and frequency domain is indicated by FFT – Fast Fourier transformation. After a transformation back to the time domain (IFFT), the broadband impulse response is obtained. The broadband impulse response is further processed to obtain the $L(t)$ function as defined in formula (1) for each fractional-octave-band. Figure B.3 is only meant for illustrating the process of signal processing. For example, the filtering to obtain fractional-octave-band responses may be done in the frequency domain as long as the requirements in 5.3.2 are satisfied.

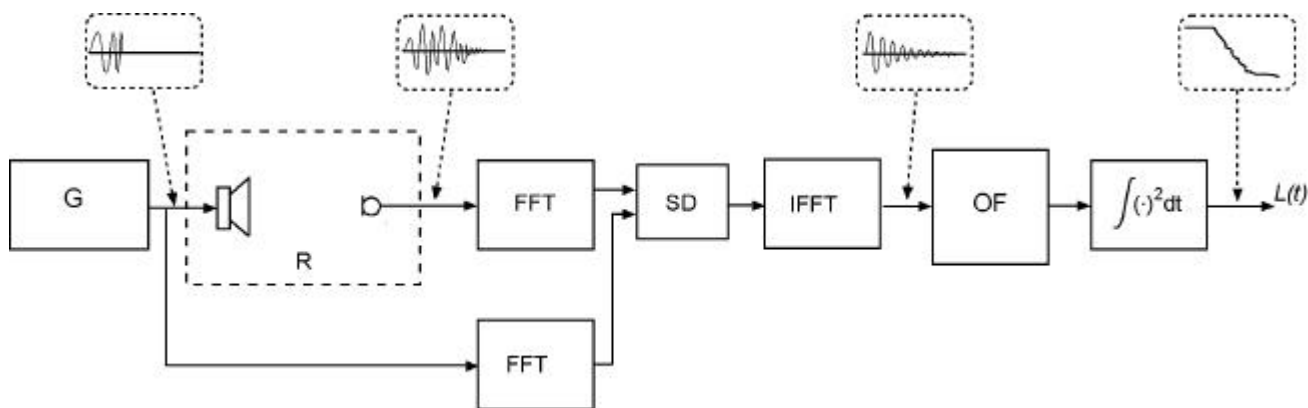

Key

- G sweep generator
- R room
- FFT Fourier Transformation
- IFFT Inverse Fourier Transformation
- SD Spectral division
- OF fractional-octave filter

Figure B.3 — Spectral division

A number of precautions have to be taken in the deconvolution process. If a Fast Fourier transformation is used, precautions against circular convolutions have to be taken. Further, the spectral division may include frequencies in the denominator with very little energy and precautions have to be taken in order not to enhance the extraneous noise accompanying the measured response at these frequencies. This will often be the case close to the boundary of the sweep range.

As the technique described here makes use of a non-periodic excitation signal, the most appropriate way to obtain the impulse response is a linear (i.e. non-circular) deconvolution. The linear deconvolution can be accomplished most simply by direct deconvolution, or if using spectral division by extending the excitation signal and the recorded response with zeros to double their previous size (zero-padding).

When the excitation is a sweep from lower to higher frequencies, the response to harmonic components will appear before the main excitation at the same frequency. After the linear deconvolution, the responses to harmonic components in the excitation will appear at negative time and may easily be removed (see [9] for further information).

When spectral division is applied, the excitation and the response are submitted to an FFT and the spectrum of the response is then divided by the spectrum of the excitation signal. An IFFT yields the desired impulse response in which the second half, corresponding to negative arrival times, can be disregarded. As described in [8], this method may also be used to remove the effects of harmonic distortion in the excitation channel.

Alternatively to the linear deconvolution, a circular deconvolution using an FFT size equal to the acquisition time may be employed. In this case, however, the distortion products could smear into the decay of the impulse response. This means that the length of the excitation signal has to be chosen sufficiently longer than the decay time. The distortion products will then appear in the noise floor where they can be safely discarded by windowing without affecting the reverberant tail.

There is an important difference concerning the noise floor in the impulse responses obtained by linear and circular deconvolution. Using a circular deconvolution results in a noise floor that is basically constant, up to the point where the first distortion products appear. The linear deconvolution, however, yields a decaying noise tail that is increasingly low-pass filtered towards its end. This stems from the fact that this last part of the deconvolution result originates from steady noise convolved with a sweep in reverse order (i.e. from high to low frequencies). The user should be aware of this affect and not confound the decreasing noise floor with the reverberant tail of the room.

B.6 Signal-to-noise ratio

The obtained effective signal-to-noise ratio depends on a number of factors in addition to the extraneous noise level like the amplitude of excitation, the sweep rate and the algorithms for the signal processing. Doubling the duration of the sweep will normally lead to an increase in the effective signal-to-noise ratio by 3 dB. Although the signal to noise ratio may be enhanced by averaging more impulse responses, this method is in general not recommended as it will lead to an increased sensitivity for changes in the environmental conditions. However, most of such environmental effects are observed at levels below 30 dB from the peak level.

B.7 Time invariance

B.7.1 General

Time variance in the system to be measured can lead to unreliable results and limit the achieved effective signal-to-noise ratio. Time invariance is a crucial assumption in the development of the new measurement methods and shall always be regarded.

The sensitivity to change in the environmental conditions depends on the applications. Most effects related to modest time variance are seen at levels below 30 dB from the peak level of the impulse response. It will

therefore seldom affect a level measurement, but can give an unreliable reverberation time. For other applications requiring a huge dynamic range, the sensitivity can be even larger.

B.7.2 Movement

All excitation sources, reflectors, microphones, other equipment or room boundaries shall be stationary and shall not be moved during a measurement.

B.7.3 Environmental conditions

B.7.3.1 Temperature

Currently, little information is available on the requirement to temperature stability when applying the swept-sine method described in this Annex. However, there is clear evidence that the method is far less sensitive than the method described in Annex A to a change in the temperature during a measurement. To be on the safe side, the user shall try to keep the environmental conditions stable during the measurement.

B.7.3.2 Maximum wind speed (outdoor measurements)

Currently, little information is available on the influence of wind when applying the swept-sine method described in this Annex. However, there is clear evidence that the method is far less sensitive than the method described in Annex A. To be on the safe side, the user shall try to keep the environmental conditions stable during the measurement.

B.7.4 Distortion

The effect of distortion in the excitation channel depends strongly on the algorithms used in the processing of the signal. As described in B.5, methods are available which can reduce the effect of harmonic distortion significantly. The user is strongly encouraged to use such methods, which normally will enhance the effective signal to noise ratio and allow the acoustic source to be operated close to its maximum levels.

Some sources of nonlinearity can generate non- or sub-harmonic distortions (e.g. rattling) and should be kept at a low level.

B.8 Periodic and repeated sweeps

In principle, a periodic sweep may be used for the excitation. In this case the period shall be equal or longer than the reverberation time as required in formula (10). However, it is regarded that application of repeated sweeps leads to an enhanced sensitivity to the environmental conditions. It is therefore recommended to use a single sweep with longer duration to enhance the signal-to-noise ratio instead of using periodic sweeps. If used, the environmental conditions required in Annex A shall be followed.

Bibliography

- [1] Schroeder, M.R., "New Method of Measuring Reverberation Time". J. Acoust. Soc. Am., vol. 37 (1965) pp. 409 – 412.
- [2] Schroeder, M.R., "Integrated-Impulse Method Measuring Sound Decay without Using Impulses". J. Acoust. Soc. Am., vol. 66 (1979) pp. 497 – 500.
- [3] Borish, J. and Angell, J.B., "An Efficient Algorithm for Measuring the Impulse Response Using Pseudorandom Noise". J. Audio Eng. Soc., vol. 31 (1983) pp. 478 – 488.
- [4] Lundeby, A., T., Vigran, E., Bietz, H. and Vorländer, M.: "Uncertainty of Measurements in Room Acoustics", *Acoustica*, vol. 81 (1995), pp 344 – 355.
- [5] Vorländer, M. and Kob, M.: "Practical Aspects of MLS Measurements in Building Acoustics". *Applied Acoustics*, vol. 52 (1997) pp. 239-258.
- [6] Horvei, B., Olsen, H. and Ustad, A.: "Nordtest project on MLS based on method for sound insulation measurements". SINTEF Report STF40 A98008, Trondheim 1998.
- [7] Bradley, J.S.: "Optimizing the Decay range in Room Acoustics Measurements using Maximum-Length-Sequence Techniques". J. Audio Engineering Soc., vol. 44 (1996) pp. 266 – 273.
- [8] Müller, S. and Massarani, P.: "Transfer-Function Measurement with Sweeps". J. Audio Eng. Soc., vol. 49 (2001) pp. 443-471.
- [9] Farina, A.: "Simultaneous measurement of impulse response and distortion with a swept-sine technique". AES 108th Convention, Paris, 2000 February 19-22, Preprint 5093.
- [10] Vorländer, M.: "Categorization of modern measurement techniques in building acoustics". Inter-Noise 2001, The Hague, Proceedings pp. 2145-2154 (2001).
- [11] Rife, D.D. and Vanderkooy, J.: "Transfer-Function Measurement with Maximum-Length Sequences". J. Audio Eng. Soc., vol. 37 (1989) pp. 419 – 443.

ISO 3382, *Acoustics – Measurement of the reverberation time of rooms with reference to other acoustical parameters*.

ISO/CD 3382-2, *Acoustics – Measurement of reverberation time – Part 2: Ordinary rooms*.

ISO/DIS 10848 (all parts), *Acoustics – Laboratory measurements of the flanking transmission of airborne and impact noise between adjoining rooms*.