



**Avant-projet de norme soumis à enquête probatoire jusqu'au :
31 MARS 2005**

Pr NF EN ISO 140-18

Indice de classement : S 31-049-18

T1 Acoustique

T2 Mesurage de l'isolation acoustique des immeubles et des éléments de construction

T3 Partie 18 : Mesurage en laboratoire du bruit généré par la pluie sur les éléments de construction

E : Acoustics – Measurement of sound insulation in buildings and of building elements – Part 18 : Laboratory measurement of sound generated by rainfall on building elements

D : Akustik – Messung der Schalldämmung in Gebäuden und von Bauteilen – Teil 18 : Messung des durch Regenfall auf Bauteilen verursachten Schalls im Prüfstand

Avant-projet de norme française homologuée

Remplace :

Correspondance

Analyse

Modifications

Norme française

NF EN ISO 140-18

Indice de classement : S 31-049-18

ICS :

T1 Acoustique

T2 Mesurage de l'isolation acoustique des immeubles et des éléments de construction

T3 Partie 18 : Mesurage en laboratoire du bruit généré par la pluie sur les éléments de construction (DIS 140-18 : 2004)

E : Acoustics — Measurement of sound insulation in buildings and of building elements — Part 18: Laboratory measurement of sound generated by rainfall on building elements (DIS 140-18 : 2004)

D : Akustik — Messung der Schalldämmung in Gebäuden und von Bauteilen — Teil 18: Messung des durch Regenfall auf Bauteilen verursachten Schalls im Prüfstand (DIS 140-18 : 2004)

Norme française homologuée par décision du Directeur Général d'AFNOR le pour prendre effet le .

Correspondance

La norme européenne EN ISO 140-18 : 200X a le statut d'une norme française.

Analyse

Le présent document spécifie le mesurage en laboratoire de la transmission des bruits de choc des toits, des systèmes de toiture/plafond et des lanterneaux produits sous une pluie artificielle. Les résultats obtenus peuvent être servir à l'évaluation du bruit produit par la pluie sur un élément de construction donné dans une pièce ou un espace placé sous cet élément.

Descripteurs

Thésaurus International Technique :

Modifications

Corrections

E:\AAARUTMAN\AAAnnée 2005\Dossiers projets et normes\Acoustique\NF_EN_ISO_140-18_(2004-12)F.doc

Membres de la commission de normalisation

Président : M REHFELD

Secrétariat : M RUTMAN – BNTB

M	AFLALO	BRUEL et KJAER
M	ARCE	BRUEL et KJAER
MME	ARNAUD	SMAC ACIEROID
MME	BECKER	AFNOR
M	BERGER	CTTB
M	BERNARD	MINISTERE DE LA DEFENSE - STBFT
MME	BESSEYRIAS	SOLLAC LORRAINE
M	BRIDIER	SNFA
M	CHATELAIN	STR PVC
M	CHENE	CSTB
M	CHEVALDONNET	UNION DES INDUSTRIES DU BOIS
M	CYROT	SNI
M	DUTILLEUX	LRPC Strasbourg
M	FRANCOIS-BRAZIER	SAINT-GOBAIN PAM
M	GAMBA	ACOUSTIQUE GAMBA ET ASSOCIES
MME	GAULUPEAU	BUREAU VERITAS
M	GUILBERT	FILMM - SAINT-GOBAIN ISOVER
M	HAJEWSKI	TARKETT SOMMER
M	HUGUES	ALPHACAN SRA
M	LECOCQ	CIAL
M	LOUWERS	IMPEDANCE SA
M	MEISSER	SNI
M	OZOUF	SNPA - BPB-PLACO

M	PERSUY	SNPA
M	PINCON	BNTEC
M	REHFELD	CSFVP - SAINT GOBAIN GLASS
M	REIGNER	CEBTP
M	ROLAND	CSTB
M	SAUVAGE	CERIB
M	SERVANT	SOCOTEC
MME	SOULIER	METLTM - DGUHC
M	TISSEYRE	TISSEYRE ET ASSOCIES
M	TIZIANEL	LAFARGE PLATRES
M	VANLENTIN	MINISTERE DE L'ENVIRONNEMENT - Mission BRUIT
M	VAN DEN BERGHE	FILMM - ROCKWOOL
M	VAYSSIE	FILMM - OWENS CORNING ALCOPOR
MME	VILLENAVE	CTBA
M	VILLOT	CSTB

Avant-propos

Références aux normes françaises

La correspondance entre les normes mentionnées à l'article "Références normatives" et les normes françaises identiques est la suivante :

EN ISO 140-1	NF EN ISO 140-1	(indice de classement : S 31-049-4)
EN ISO 140-3	NF EN ISO 140-3	(indice de classement : S 31-049-3)
EN ISO 354	NF EN ISO 354	(indice de classement : S 31-003)
EN ISO 15186-1	NF EN ISO 15186-1	(indice de classement : S 31-098-1)
CEI 60721-2-2	<i>NF E 60721-2-2</i>	<i>(indice de classement : C 20-002-2)</i>
CEI 61260	NF EN 61260	(indice de classement : C 97-010)
CEI 61672-1	NF EN 61672-1	(indice de classement : S 31-009-1)
CEI 61672-2	NF EN 61672-2	(indice de classement : S 31-009-2)
CEI 60942	NF EN 60942	(indice de classement : S 31-139)
prEN ISO 10848-1	prNF EN ISO 10848-1	(indice de classement : S 31-097-1PR)

January 2005

ICS

English version

Acoustics - Measurement of sound insulation in buildings and of building elements - Part 18: Laboratory measurement of sound generated by rainfall on building elements (ISO/DIS 140-18:2005)

Acoustique - Mesurage de l'isolation acoustique des immeubles et des éléments de construction - Partie 18: Mesurage en laboratoire du bruit généré par la pluie sur les éléments de construction (ISO/DIS 140-18:2005)

This draft European Standard is submitted to CEN members for parallel enquiry. It has been drawn up by the Technical Committee CEN/TC 126.

If this draft becomes a European Standard, CEN members are bound to comply with the CEN/CENELEC Internal Regulations which stipulate the conditions for giving this European Standard the status of a national standard without any alteration.

This draft European Standard was established by CEN in three official versions (English, French, German). A version in any other language made by translation under the responsibility of a CEN member into its own language and notified to the Management Centre has the same status as the official versions.

CEN members are the national standards bodies of Austria, Belgium, Cyprus, Czech Republic, Denmark, Estonia, Finland, France, Germany, Greece, Hungary, Iceland, Ireland, Italy, Latvia, Lithuania, Luxembourg, Malta, Netherlands, Norway, Poland, Portugal, Slovakia, Slovenia, Spain, Sweden, Switzerland and United Kingdom.

Warning : This document is not a European Standard. It is distributed for review and comments. It is subject to change without notice and shall not be referred to as a European Standard.



EUROPEAN COMMITTEE FOR STANDARDIZATION
COMITÉ EUROPÉEN DE NORMALISATION
EUROPÄISCHES KOMITEE FÜR NORMUNG

Management Centre: rue de Stassart, 36 B-1050 Brussels

Foreword

This document (prEN ISO 140-18:2005) has been prepared by Technical Committee ISO/TC 43 "Acoustics" in collaboration with Technical Committee CEN/TC 126 "Acoustic properties of building elements and of buildings", the secretariat of which is held by AFNOR.

This document is currently submitted to the parallel Enquiry.

Endorsement notice

The text of ISO 140-18:2005 has been approved by CEN as prEN ISO 140-18:2005 without any modifications.



DRAFT INTERNATIONAL STANDARD ISO/DIS 140-18

ISO/TC 43/SC 2

Secretariat: DIN

Voting begins on:
2005-01-06

Voting terminates on:
2005-06-06

INTERNATIONAL ORGANIZATION FOR STANDARDIZATION • МЕЖДУНАРОДНАЯ ОРГАНИЗАЦИЯ ПО СТАНДАРТИЗАЦИИ • ORGANISATION INTERNATIONALE DE NORMALISATION

Acoustics — Measurement of sound insulation in buildings and of building elements —

Part 18:

Laboratory measurement of sound generated by rainfall on building elements

Acoustique — Mesurage de l'isolation acoustique des immeubles et des éléments de construction —

Partie 18: Mesurage en laboratoire du bruit généré par la pluie sur les éléments de construction

ICS 91.120.20

ISO/CEN PARALLEL ENQUIRY

The CEN Secretary-General has advised the ISO Secretary-General that this ISO/DIS covers a subject of interest to European standardization. **In accordance with the ISO-lead mode of collaboration as defined in the Vienna Agreement, consultation on this ISO/DIS has the same effect for CEN members as would a CEN enquiry on a draft European Standard.** Should this draft be accepted, a final draft, established on the basis of comments received, will be submitted to a parallel two-month FDIS vote in ISO and formal vote in CEN.

In accordance with the provisions of Council Resolution 15/1993 this document is circulated in the English language only.

Conformément aux dispositions de la Résolution du Conseil 15/1993, ce document est distribué en version anglaise seulement.

To expedite distribution, this document is circulated as received from the committee secretariat. ISO Central Secretariat work of editing and text composition will be undertaken at publication stage.

Pour accélérer la distribution, le présent document est distribué tel qu'il est parvenu du secrétariat du comité. Le travail de rédaction et de composition de texte sera effectué au Secrétariat central de l'ISO au stade de publication.

THIS DOCUMENT IS A DRAFT CIRCULATED FOR COMMENT AND APPROVAL. IT IS THEREFORE SUBJECT TO CHANGE AND MAY NOT BE REFERRED TO AS AN INTERNATIONAL STANDARD UNTIL PUBLISHED AS SUCH.

IN ADDITION TO THEIR EVALUATION AS BEING ACCEPTABLE FOR INDUSTRIAL, TECHNOLOGICAL, COMMERCIAL AND USER PURPOSES, DRAFT INTERNATIONAL STANDARDS MAY ON OCCASION HAVE TO BE CONSIDERED IN THE LIGHT OF THEIR POTENTIAL TO BECOME STANDARDS TO WHICH REFERENCE MAY BE MADE IN NATIONAL REGULATIONS.

PDF disclaimer

This PDF file may contain embedded typefaces. In accordance with Adobe's licensing policy, this file may be printed or viewed but shall not be edited unless the typefaces which are embedded are licensed to and installed on the computer performing the editing. In downloading this file, parties accept therein the responsibility of not infringing Adobe's licensing policy. The ISO Central Secretariat accepts no liability in this area.

Adobe is a trademark of Adobe Systems Incorporated.

Details of the software products used to create this PDF file can be found in the General Info relative to the file; the PDF-creation parameters were optimized for printing. Every care has been taken to ensure that the file is suitable for use by ISO member bodies. In the unlikely event that a problem relating to it is found, please inform the Central Secretariat at the address given below.

Copyright notice

This ISO document is a Draft International Standard and is copyright-protected by ISO. Except as permitted under the applicable laws of the user's country, neither this ISO draft nor any extract from it may be reproduced, stored in a retrieval system or transmitted in any form or by any means, electronic, photocopying, recording or otherwise, without prior written permission being secured.

Requests for permission to reproduce should be addressed to either ISO at the address below or ISO's member body in the country of the requester.

ISO copyright office
Case postale 56 • CH-1211 Geneva 20
Tel. + 41 22 749 01 11
Fax + 41 22 749 09 47
E-mail copyright@iso.org
Web www.iso.org

Reproduction may be subject to royalty payments or a licensing agreement.

Violators may be prosecuted.

Contents

	Page
Introduction	iv
Foreword	v
1 Scope.....	1
2 Normative references	1
3 Terms and definitions.....	2
4 Equipment.....	3
5 Test arrangement.....	3
6 Classification of rain types	4
7 Test equipment and procedure	4
8 Expression of results.....	9
9 Test report	9
Annex A (normative) Specifications for a tank with perforated base	11
Annex B (normative) Reference test specimens.....	13
Bibliography	15

Introduction

This International Standard prescribes a laboratory method for the measurement of sound generated by rainfall on building elements using artificial raindrops produced by a water tank.

Ideally one should expose the test specimen to real rain for such measurements. But real rain is neither steady nor continuous with respect to time. Furthermore raindrops can vary in diameter due to several factors including geographic location which will introduce variability in measured values. One can, however, use real raindrops as a means of validation of measured results obtained with artificial raindrops by building a test room in an unobstructed location. For such research, it is important that the rain sensor or rain gauge is capable of measuring constant short interval rainfall rates. In the absence of drop size information, repeatability and fluctuations of the measured sound levels with real rain can be investigated by undertaking measurements separated by a time interval of at least 24 hours

Artificial raindrop generation systems, other than the water tank used in this standard, exist, such as hydraulic spray nozzles; however, so far, nozzles corresponding to the specifications given in this standard are not commercially available: indeed, their flow rate being too high when the drop diameter is correct or the drop diameter being too small when the flow rate is correct. As a result, only the water tank solution is proposed in this standard.

An alternative to real rain or artificial raindrops is the dry mechanical excitation of the test specimen. Researchers have used different methods such as excitation by an impact hammer and other mechanical impacting simulators with an aim to simulate noise of real rain. Such methods invariably suffer from the drawback that the noise source does not generate both the sound levels and the sound spectra that compare well with corresponding values generated by the real rain on various types of test specimens. Further research work to develop mechanical methods of rain noise generation that can match both the sound levels and spectra of real rain is encouraged.

D
R
A
F
T

Foreword

ISO (the International Organization for Standardization) is a worldwide federation of national standards bodies (ISO member bodies). The work of preparing International Standards is normally carried out through ISO technical committees. Each member body interested in a subject for which a technical committee has been established has the right to be represented on that committee. International organizations, governmental and non-governmental, in liaison with ISO, also take part in the work. ISO collaborates closely with the International Electrotechnical Commission (IEC) on all matters of electrotechnical standardization.

International Standards are drafted in accordance with the rules given in the ISO/IEC Directives, Part 2.

The main task of technical committees is to prepare International Standards. Draft International Standards adopted by the technical committees are circulated to the member bodies for voting. Publication as an International Standard requires approval by at least 75 % of the member bodies casting a vote.

Attention is drawn to the possibility that some of the elements of this document may be the subject of patent rights. ISO shall not be held responsible for identifying any or all such patent rights.

ISO 140-18 was prepared by Technical Committee ISO/TC 43, *Acoustics*, Subcommittee SC 2, *Building acoustics*.

ISO 140 consists of the following parts, under the general title *Acoustics — Measurement of sound insulation in buildings and of building elements*:

- *Part 1: Requirements for laboratories*
- *Part 2: Determination, verification and application of precision data*
- *Part 3: Laboratory measurements of airborne sound insulation of building elements*
- *Part 4: Field measurements of airborne sound insulation between rooms*
- *Part 5: Field measurements of airborne sound insulation of facade elements and facades*
- *Part 6: Laboratory measurements of impact sound insulation of floors*
- *Part 7: Field measurements of impact sound insulation of floors*
- *Part 8: Laboratory measurements of the reduction of transmitted impact noise by floor coverings on a standard floor*
- *Part 9: Laboratory measurement of room-to-room airborne sound insulation of a suspended ceiling with a plenum above it*
- *Part 10: Laboratory measurement of airborne sound insulation of small building elements*
- *Part 11: Laboratory measurements of the reduction of transmitted impact sound by floor coverings on lightweight reference floors*
- *Part 12: Laboratory measurement of room-to-room airborne and impact sound insulation of an access floor*
- *Part 13: Guidelines*
- *Part 14: Additional requirements and guidelines for special situations in the field*

- *Part 16: Laboratory measurement of the sound reduction index improvement by additional lining*
- *Part 18: Laboratory measurement of sound generated by rainfall on building elements*

DRAFT 2005

Acoustics — Measurement of sound insulation in buildings and of building elements —

Part 18:

Laboratory measurement of sound generated by rainfall on building elements

1 Scope

This part of ISO 140 specifies a laboratory method of measurement of the impact sound insulation of roofs, roof/ceiling systems and skylights excited by artificial rainfall. The results obtained can be used for assessing the noise to be produced by rainfall on a given building element in the room or space below. The results can also be used to compare rainfall sound insulation capabilities of building elements and to design building elements with appropriate rainfall sound insulation properties.

This standard is based on measurements with artificial raindrops under controlled conditions using a water tank in a laboratory test facility in which flanking sound transmission is suppressed. Measurements using real rain, although a useful means for validation purposes, are not included because of the variable, unpredictable and intermittent nature of real rain. Other mechanical simulation methods under investigation by researchers are not sufficiently well developed at present to adequately simulate real rain both in terms of sound levels and spectra generated.

2 Normative references

The following referenced documents are indispensable for the application of this document. For dated references, only the edition cited applies. For undated references, the latest edition of the referenced document (including any amendments) applies.

ISO 140-1, *Acoustics — Measurement of sound insulation in buildings and of building elements — Part 1: Requirements for laboratory test facilities with suppressed flanking transmission*

ISO 140-3, *Acoustics — Measurement of sound insulation in buildings and of building elements — Part 3: Laboratory measurements of airborne sound insulation of building elements*

ISO 354, *Acoustics — Measurements of sound absorption in a reverberation room*

ISO 15186-1, *Acoustics — Measurement of sound insulation in buildings and of building elements using sound intensity — Part 1: Laboratory measurements*

IEC 60721-2-2, *Classification of environmental conditions — Part 2: Environmental conditions appearing in nature — Precipitation and wind*

IEC 61260, *Electroacoustics — Octave-band and fractional-octave-band filters*

IEC 61672-1, *Electroacoustics — Sound level meters — Part 1: Specifications*

IEC 61672-2, *Electroacoustics — Sound level meters — Part 2: Pattern evaluation tests*

IEC 60942, *Electroacoustics — Sound calibrators*

ISO/DIS 10848-1, *Acoustics — Laboratory measurement of the flanking transmission of airborne and impact noise between adjoining rooms — Part 1: Frame document*

3 Terms and definitions

For the purposes of this document, the following terms and definitions apply.

3.1

average sound pressure level in a room

ten times the common logarithm of the ratio of the space and time average of the squared sound pressure to the square of the reference sound pressure, the space average being taken over the entire room with the exception of those parts where the direct radiation of a sound source or the near field of the boundaries (walls, etc.) is of significant influence

The quantity is denoted by L and is expressed in decibels.

If a continuously moving microphone is used L is determined by

$$L = 10 \lg \frac{1/T_m \int_0^{T_m} p^2(t) dt}{p_0^2} \text{ dB} \quad (1)$$

where

p is the sound pressure, in Pascals;

p_0 is the reference sound pressure and is equal to 20 μPa ;

T_m is the integration time, in seconds.

If fixed microphone positions are used, L is determined by

$$L = 10 \lg \frac{p_1^2 + p_2^2 + \dots + p_n^2}{np_0^2} \text{ dB} \quad (2)$$

where p_1, p_2, \dots, p_n are r.m.s. sound pressures at n different positions in the room. In practice, usually the sound pressure levels L_i are measured. In this case L is determined by

$$L = 10 \lg \frac{1}{n} \sum_{i=1}^n 10^{L_i/10} \text{ dB} \quad (3)$$

where L_i are the sound pressure levels L_1 to L_n at n different positions in the room.

3.2

sound intensity level

sound-power level per unit area radiated by the test specimen into the test room below, in dB referenced to $1 \times 10^{-12} \text{ W/m}^2$

3.3

rainfall rate

depth of water layer created by spreading the rainfall on a horizontal surface in a one-hour time interval, in mm/h

3.4

volume median drop diameter

value, in millimetres, where 50 % of the total volume of water sprayed is made up of drops with diameter larger than the median value and 50 % with smaller diameter

4 Equipment

The accuracy of the sound level measurement equipment shall comply with the requirements of accuracy classes 0 or 1 specified in IEC 61672-1 and IEC 61672-2. The complete sound measuring system including the microphone shall be adjusted before each measurement using a sound calibrator which complies with the requirements of accuracy class 1 specified in IEC 60942.

The one third-octave band filters shall comply with the requirements specified in IEC 61260.

The reverberation time measurement equipment shall comply with the requirements specified in ISO 354.

5 Test arrangement

5.1 Test room

A test room without a permanent roof or with an opening in the roof for installation of the test specimens is required for these measurements; however, if the intensity method is used, then the receiving space shall meet the requirements given in section 7.4.

The requirements of the test room are based on ISO 140-1. The volume of the test room shall be at least 50 m³. The ratios of the room dimensions shall be so chosen that the natural frequencies in the low frequencies are spaced as uniformly as possible. If necessary, diffusing elements should be installed in the test room to obtain a diffuse field.

The airborne sound insulation of the walls, door(s) and floor of the test room shall be sufficiently high so that the sound field measured in the test room is only that generated by the impact excitation of the test specimen.

The background noise level in the test room shall be sufficiently low to permit the measurement of sound generated by excitation of the test specimen with artificial rainfall. The correction associated with background noise is discussed in 7.3.2.

The reverberation time in the test room should not be excessively long. It is recommended that the reverberation time in the test room be not more than 2 s at low test frequencies. If the reverberation time in the test room is too long, proceed according to ISO 140-1.

5.2 Test Specimen

5.2.1 Standard specimen and laboratory configuration

The size of the test specimen opening shall be between 10 m² and 20 m² with the length of the shorter edge being not less than 2,3 m. The test specimen shall be well sealed at the perimeter with the test room to prevent leakage sound transmission. The joints within the test specimen, if any, shall be sealed in a manner as similar as possible to the actual construction.

For skylights, the preferred dimensions are 1 500 mm × 1 250 mm with limit deviations of ± 50 mm. Skylights shall be installed in a filler slab construction of sufficiently high airborne sound insulation and well sealed at the perimeter such that the sound field measured in the test room is only that generated by the impact excitation of the test specimen.

The default slope of the test specimen is 5° for roofs and 30° for skylights with a minimum height to keep the niche effect as limited as possible (see Figure A.2); for other slopes, see 5.2.2.

5.2.2 Other configurations

Specimens of surface area less than 1 m² are not recommended. The slope of the test specimen can be the actual slope for specific situations/systems, if known.

6 Classification of rain types

The real rain can be classified in terms of rainfall rate, typical drop diameters and fall velocities in accordance with IEC 60721-2-2. These values are given in Table 1.

Table 1 — Classification of rain type according to IEC Standard 60721-2-2

Rainfall type	Rainfall rate mm/h	Typical drop diameter mm	Fall velocity m/s
Moderate	up to 4	0,5 – 1,0	1 – 2
Intense	up to 15	1 – 2	2 – 4
Heavy	up to 40	2 – 5	5 – 7
Cloudburst	greater than 100	> 3	> 6

7 Test equipment and procedure

This section describes the artificial rainfall types for the measurements and generation systems for artificial raindrops.

7.1 Rainfall Type

7.1.1 Standard type

The standard rainfall type used for comparison between products shall be the heavy type; it should be noted that the corresponding rainfall rate might be too high when applied to real case with lighter rain. The characteristic parameters of the artificial raindrops for this type of rainfall shall be chosen in accordance with Table 2, line 2. These values are based on Table 1 and upper limits have been chosen as larger drops produce most of the noise generated.

7.1.2 Other types

Other types of rainfall are permitted as long as their characteristics are indicated; however, if a rainfall rate lower than the heavy rain is needed, then the intense type described in Table 2, line 1 is recommended.

Table 2 — Characteristic parameters for artificial raindrops generation

Rainfall type	Rainfall rate mm/h	Volume median drop diameter mm	Fall velocity m/s
Intense	15	2,0	4,0
Heavy	40	5,0	7,0

Tolerances on the three characteristic parameters for artificial raindrops generation given in Table 2 are as follows:

- the rainfall rate shall be within ± 2 mm/h of the rainfall rate given in Table 2;
- 50% of the drops should be within $\pm 0,5$ mm of the volume median drop diameter given in Table 2;
- 50% of the drops should be within ± 1 m/s of the fall velocity given in Table 2.

7.2 Artificial raindrop generation

7.2.1 General

The artificial raindrop generation system, when connected to a water supply, is capable of generating water drops of uniform diameter in a full water spray pattern. The water supply to generate artificial raindrops can be either closed loop type or continuous type that enables continuous generation of constant diameter water drops over a long period of time.

After impacting on the test specimen, the water shall be drained to eliminate extraneous noise generation. The water supply pump shall be either located well away from the test room or housed in an acoustic enclosure so that its contribution to the background noise does not make rainfall measurements invalid. For smaller test specimens such as skylights, a single position for the artificial raindrop generation system is sufficient. For larger test specimens (more than 3 m²), three positions for the artificial raindrop generation system shall be chosen. The location of the impact of artificial raindrops on the test specimen should be slightly off-centre to avoid symmetry.

7.2.2 Artificial raindrop generation system

The artificial raindrop system shall be a tank with a perforated base capable of generating water drops with the specification given in Table 2 in a full spray pattern. The perforations on the tank base should be uniformly distributed over an minimum area of 1 m² (see Figure A.1).

The water supply pressure and the number of perforations shall be chosen so that the water height in the tank is constant and allows the rainfall rate given in Table 2 to be generated by the perforated tank. The perforation characteristics (diameter) of the tank base shall be chosen so that water drops with volume median drop diameter given in Table 2 are produced by the perforated tank. The fall height of the artificial raindrops shall be adjusted such that the either measured or theoretically calculated fall velocities based on perforation dimensions, water pressure and fall height are as given in Table 2. The specifications, dimensions and other design parameters of tanks with a perforated base that meet the above requirements are given in Annex A as well as a sketch showing a typical test arrangement (see Figure A.2).

7.2.3 Calibration of the raindrop generation system

The artificial raindrop generation system shall be calibrated.

If a water tank system is used and therefore follows the geometrical characteristics given in Annex A, then only the rainfall rate shall be checked by collecting the water over a given area during a precisely measured time period; the measurement of the rainfall rate allows a quick and simple method for periodic verification of the artificial raindrop generation system.

If another system is selected in order to generate other types of rain fall, the rainfall type characteristics, i.e. the drop size, the drop velocity and the rainfall rate, shall be given by the manufacturer; if they are not available they should be measured. Here again, the measurement of the rainfall rate allows a quick and simple method for periodic verification of the artificial raindrop generation system.

NOTE There are several non-intrusive methods to measure drop size and drop velocity, as for example, imaging analysers consisting of a light source (typically a strobe light), a video camera, and a computer, or phase Doppler particle analyzers consisting of a transmitter, a receiver, a signal processor and a computer.

7.3 Determination of the sound intensity level (indirect method)

7.3.1 Sound pressure level measurements

Prior to the commencement of sound pressure level measurements, a steady artificial rainfall rate shall be maintained over the test specimen for at least 5 minutes.

While maintaining the steady artificial rainfall rate, sound-pressure levels in the test room shall be averaged either with a rotating microphone boom or at fixed microphone positions. The sound pressure levels at different positions shall be averaged on an energy basis.

The following separating distances are minimum values and shall be exceeded where possible:

- 0,7 m between microphone positions;
- 0,7 m between any microphone position and room boundaries or diffusers;
- 1,0 m between any microphone and the test specimen.

When using fixed microphones, a minimum of five microphone positions shall be used in the test room; these shall be distributed within the maximum permitted space and spaced uniformly in the test room. The averaging time at each individual microphone position shall be at least 6 s at each frequency band with centre frequencies below 400 Hz. For bands of higher centre frequencies, it is permissible to decrease the averaging time to not less than 4 s.

The frequency range considered is the one specified in ISO 140-3, corresponding to 1/3 octave 100 Hz to 5 000 Hz with a complement, if necessary, from 1/3 octaves 50 Hz to 80 Hz.

When using a moving microphone, the sweep radius shall be at least 1 m. The plane of the traverse shall be inclined in order to cover a large proportion of the permitted room space and shall not lie in any plane within 10° of a room surface. The duration of the traverse period shall not be less than 15 s. The averaging time shall cover a whole number of traverses and shall not be less than 30 s.

When using three positions of the rain generation system (i.e. for large tests specimen), the three corresponding sound pressure levels should be added energetically.

7.3.2 Correction for background noise

The background noise levels shall be measured to ensure that the observations in the test room are not affected by extraneous noise. The background level shall be at least 6 dB (and preferably more than 15 dB) below the measured sound pressure levels with artificial rainfall noise signal and background noise combined. When in any frequency band the measured sound-pressure level in the test room is smaller than 15 dB but greater than 6 dB, calculate corrections to the signal level according to the equation

$$L = 10 \lg \left(10^{L_{sb}/10} - 10^{L_b/10} \right) \text{ dB} \quad (4)$$

where

- L is the adjusted signal level, in decibels;
- L_{sb} is the level of signal and background combined, in decibels;
- L_b is the background noise level, in decibels.

If the difference in levels is less than or equal to 6 dB in any of the frequency bands, use the correction 1,3 dB corresponding to the difference of 6 dB. In that case, the results shall be reported so that it clearly appears that the reported values are the limit of measurements.

7.3.3 Conversion of sound pressure levels to sound intensity levels

The sound-pressure level measured according 7.3.1 shall be converted to the sound-power level per unit area or sound-intensity level, L_i , radiated by the test specimen for each one-third octave band centre frequency by the following equation

$$L_i = L_{pr} - 10 \lg (T/T_0) + 10 \lg (V/V_0) - 14 - 10 \lg (S/S_0) \quad (5)$$

where

L_{pr} is the averaged sound-pressure level in the test room, in decibels;

T is the reverberation time of the test room, in seconds;

T_0 is the reference time (= 1 s);

V is the volume of the test room, in m^3 ;

V_0 is the reference volume (= 1 m^3);

S is the area of the test specimen directly excited by the rainfall, in m^2 ;

S_0 is the reference area (= 1 m^2).

The reverberation time of the test room shall be measured by measuring the decay rates using the interrupted noise method as described in the ISO 354.

The one-third octave band levels, L_{1j} , can be combined and converted to yield A-weighted sound intensity level L_{1A} by applying the standardised A-weighting factors as follows:

$$L_{1A} = 10 \lg \sum_{j=1}^{j_{\max}} 10^{0,1(L_{1j} + C_j)} \quad (6)$$

where

L_{1j} is the level in the j th one third-octave band;

$j_{\max} = 18$ and the C_j values for one-third octave band centre frequencies between 100 Hz and 5 000 Hz are given in Table 3.

Table 3 — Values of j and C_j for one-third octave bands

j	One-third octave band centre frequency Hz	C_j dB
1	100	-19,1
2	125	-16,1
3	160	-13,4
4	200	-10,9
5	250	-8,6
6	315	-6,6
7	400	-4,8
8	500	-3,2
9	630	-1,9
10	800	-0,8
11	1 000	0
12	1 250	0,6
13	1 600	1
14	2 000	1,2
15	2 500	1,3
16	3 150	1,2
17	4 000	1
18	5 000	0,5

If octave band levels L_{Oct} are to be determined, these values have to be calculated for each octave band based on the three values of the corresponding third octave bands, as follows:

$$L_{\text{Oct}} = 10 \lg \left(\sum_{j=1}^3 10^{0,1(L_{1/3\text{Oct},j})} \right) \tag{7}$$

7.4 Direct measurement of sound intensity

As an alternative to using the sound pressure level measurement method, the sound intensity method can be employed to directly determine the sound intensity levels (see ISO 15186-1). The test room, referred to as the receiving room in ISO 15186-1, shall then be any room meeting the requirements of the field indicator, F_{pl} , and the background noise as discussed in ISO 15186-1, 6.4.2 and 6.5.

7.5 Normalization using a reference test specimen

7.5.1 Reference test specimen

For comparison purposes a reference test specimen as described in Annex B, mounted according to the specification given in 5.2.1 and submitted to the heavy rain type as described in 7.1 shall be measured (see details in Annex B).

7.5.2 Normalization

The sound intensity levels L_I obtained for the specimen tested according to 7.3.3 or 7.4 are normalized with respect to the results obtained for the test reference specimen, using the correction term ΔL_{Ic} defined in Annex B and leading to the normalized sound intensity levels defined by

$$L_{I \text{ normalized}} = L_I - \Delta L_{Ic} \quad (8)$$

The one-third octave band levels, $L_{I \text{ normalized}}$, can then be combined and converted to yield the A-weighted sound intensity level $L_{IA \text{ normalized}}$ by applying the standardised A-weighting factors as seen in 7.3.3.

8 Expression of results

The sound intensity levels (L_I) and A-weighted sound intensity levels (L_{IA}) as a function of frequency should be expressed with a precision to 0,1 dB and presented in a table and a graph. The graphs in the test report should indicate values in decibels as a function of frequency on a logarithmic scale and the following dimensions should be used:

5 mm per third octave band;

20 mm per 10 dB.

The global A-weighted sound intensity level L_{IA} , and the corresponding rainfall rate should also be given.

The normalized sound intensity levels ($L_{I \text{ normalized}}$) as a function of frequency should also be expressed with a precision to 0,1 dB and presented in the table and the graph. The global A-weighted normalized sound intensity level $L_{IA \text{ normalized}}$ should also be provided.

9 Test report

The test report shall include the following information:

- a) reference to this part of ISO 140;
- b) name and the address of the testing laboratory;
- c) manufacturer's name and product identification;
- d) name and the address of the organisation or person who ordered the test;
- e) date of test;
- f) description of the test specimen with sectional drawings and mounting conditions including size, thickness, mass per unit area, curing time and condition of components, statement indicating who mounted the test object (test institute or manufacturer);
- g) details of the test room, its dimension and volume, materials of construction, and diffusers;
- h) method of attachment of the test specimen to the walls of the test room, dimensions and slope of the test specimen;
- i) equipment and methodology used for measurements of sound-pressure levels and rainfall rates;
- j) description of artificial rainfall generation system including its characteristics, and, if the system differs from the water tank described in Annex A, the methodology used for the measurements of the rainfall rate, fall velocity and drop diameter (and spread angle if applicable), as well as the results and date of these measurements;

- k) rainfall type and rainfall rate in mm/h;
- l) position of the artificial rainfall generation system with respect to the test specimen, as well as the area and location of the test specimen sprayed (for large specimen, this has to be given for all three different positions of the artificial rainfall generation system);
- m) temperature and humidity level in the test room, as well as the temperature of the rainwater;
- n) sound intensity levels (L_I) and A-weighted sound intensity levels (L_{IA}) as a function of frequency in a table and graph form, and global A-weighted sound intensity level L_{IA} as well as the corresponding rainfall rate;
- o) normalized sound intensity levels ($L_{I \text{ normalized}}$) as a function of frequency in a table and graph form, and the global A-weighted normalized sound intensity level ($L_{IA \text{ normalized}}$).

DRAFT

2005

Annex A (normative)

Specification for a tank with perforated base

Two different tanks with different perforated bases are required for artificial raindrop production; one for heavy type rain (mandatory) and the second for the intense type rain (only recommended if lower rainfall rates are needed). The corresponding specifications are given in Table A.1. The tanks are made from polycarbonate plates of thickness 1 cm; the base is reinforced by metal strips.

Table A.1 – Specifications

Tank with perforated base parameters		Intense	Heavy
1	Diameter holes	0,3 mm to 0,5 mm	1 mm
2	Number of holes per unit area	Approx. 25 m ⁻²	Approx. 60 m ⁻²
3	Fall height	Approx. 1,0 m	Approx. 3,5 m
5	Volume median drop diameter	2,0 mm	5,0 mm
6	Distribution of drop size	Max. uniformity	Max. uniformity
7	Fall velocity at fall height	4,0 m/s	7,0 m/s
8	Rainfall rate	15 mm/h	40 mm/h
9	Water supply	To allow a constant height of water in the tank (1 cm to 5 cm)	

If the tank with perforated base does not correspond to the geometrical characteristics given above, then the drop size, impact velocity and rainfall rate shall be measured as mentioned in 7.2.3 and correspond to the values given in Table 2.

Tolerances on the rainfall rate, the volume median drop diameter and the fall velocity specified above are given in 7.1.

Fall height evaluated from Figure 6 in [1].

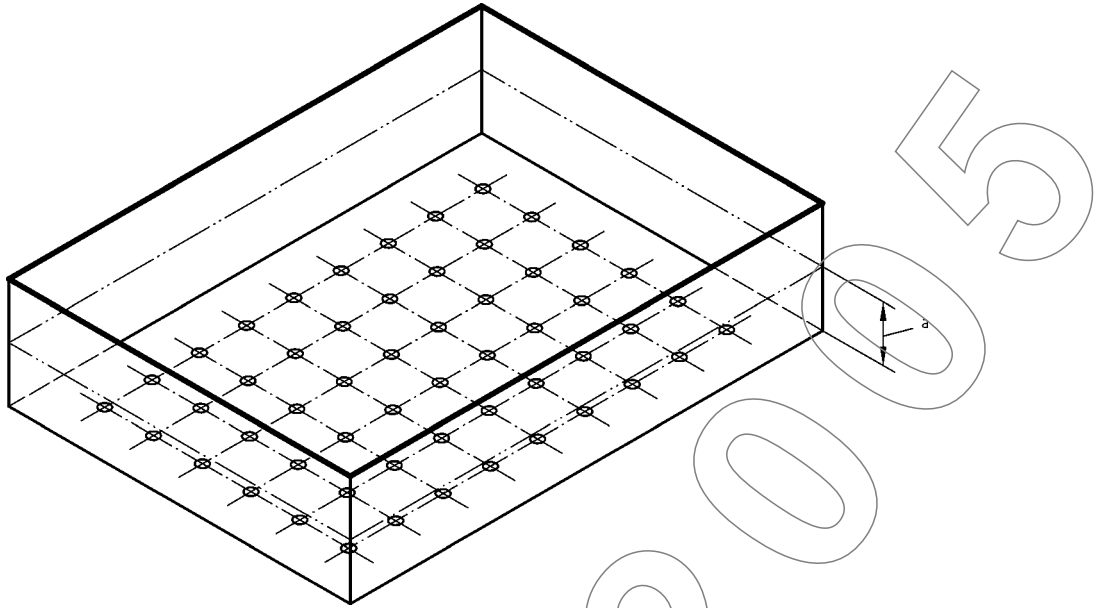

Key
 a Typical water height

Figure A.1 — Schematic of tank with perforated base

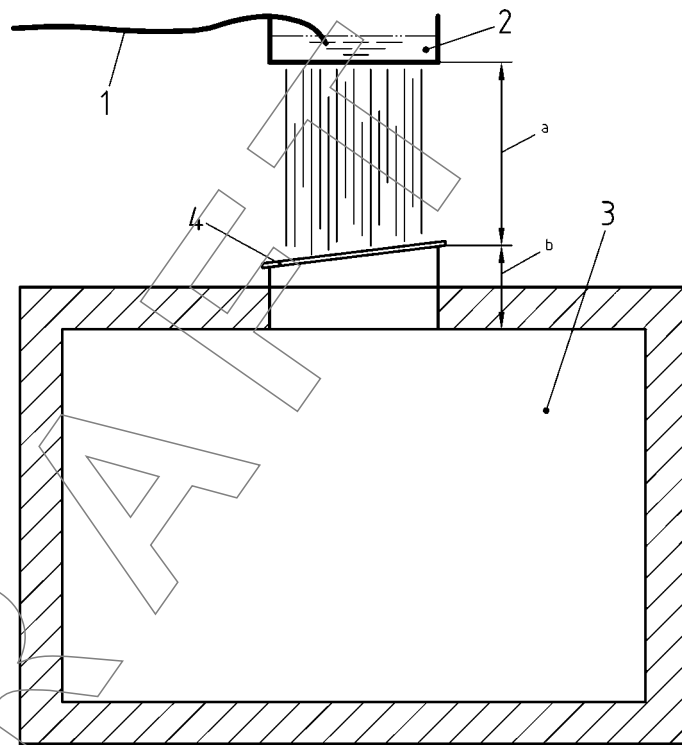

Key
 1 Water supply system
 2 Tank with perforated base
 3 Test room
 4 Test specimen
 a Fall height
 b Weight of the niche

Figure A.2 — Typical test arrangement

Annex B (normative)

Reference test specimens

B.1 General

Standard reference test specimens are described in this Annex for quality control and to check reproducibility of laboratory rain noise measurements in different laboratories. Details of the reference test specimens are as follows.

B.2 Small test specimen

The small reference test specimen is made of a single glass pane with a thickness of $(6,0 \pm 0,1)$ mm and an area of $(1\,250 \pm 50)$ mm \times $(1\,500 \pm 50)$ mm (as specified in ISO 140-1); the mounting of the glass pane is shown in ISO 140-1, Figure 1 except for the edge used for water drainage. The position of the artificial rainfall generation system is centred with respect to the test specimen.

To calibrate the mounting conditions of the reference test specimen, the structural decay time T_s shall be measured according to ISO/DIS 10848-1, 7.3 from which the total loss factor η of the reference specimen is calculated, using:

$$\eta = \frac{2,2}{f T_s} \quad (\text{B.1})$$

The sound intensity level $L_{I,\text{ref}}$, obtained according to 7.3.3 or 7.4 for the reference specimen is then corrected for the difference between the measured loss factor η and the reference loss factor η_{ref} given in Table B.1 below, using:

$$L_{I,m,\text{ref}} = L_{I,\text{ref}} + 10 \log \frac{\eta}{\eta_{\text{ref}}} \quad (\text{B.2})$$

A correction ΔL_{IC} is then calculated from the difference

$$\Delta L_{\text{IC}} = L_{I,m,\text{ref}} - L_{\text{IC ref}} \quad (\text{B.3})$$

where $L_{\text{IC ref}}$ is the reference sound intensity level for the small test specimen, given in Table B.1 below.

B.3 Large test specimen:

To be defined during the next revision of this standard.

Table B.1 — Reference loss factor and reference intensity level used for the small reference test specimen

One third octave band in Hz	Reference loss factor: $10 \lg(\eta_{\text{ref}} / \eta_0)$ ($\eta_0 = 1$) dB	Intensity levels: $L_{1,c,\text{ref}}$ dB
100	-10	45
125	-11	45
160	-11	46
200	-12	46
250	-13	47
315	-13	47
400	-14	47
500	-14	47
630	-15	47
800	-15	46
1 000	-16	44
1 250	-17	42
1 600	-17	43
2 000	-18	46
2 500	-18	51
3 150	-19	50
4 000	-19	46
5 000	-20	44

Bibliography

- [1] J. Mc Loughlin, D.J. Saunders and R.D. Ford, Noise generated by simulated rainfall on profiled steel roof structures, *Applied Acoustics*, 42 (1994) 239-255

DRAFT 2005