

Acoustical Performance of Aluminum Framed Façade Systems

Hans-Walter Bielefeld
Schüco International KG, Germany

Tejav DeGanyar
Schüco USA, USA.

Summary

With the recent environmental noise pollution concerns and the growth in the construction of residential dwellings in noisy urban areas, prescribed acoustic requirements have become more prevalent in the design of building envelopes. Aluminum framed window systems are the leading choice for modern façade construction. These systems provide a high degree of weathering reliability, installation ease, and overall economy while maintaining transparency and environmental efficiency.

In typical façades, glass covers the bulk of the exposed surface. Therefore, it is the primary source of sound energy transmission from exterior to interior. Traditionally the acoustical requirements have been dictated by the specification of the sound transmission characteristics of glass. The recent availability of double cavity insulated glass products, as well as the development of acoustical interlayers, has increased the acoustical performance of the glazing systems. Double-layer glazing strategies have also been employed to create a greater degree of sound isolation, by creating large air pockets in-between the exterior wall and an auxiliary interior glass barrier.

Aluminum and glass have comparable stiffness and density properties, which gives them roughly matching acoustical characteristics. However, with the advent of the new higher performing glass solutions, the framing elements becomes more critical for limiting of the sound transfer. This study investigates the noise transmission characteristics of aluminum and glass façade systems. It concentrates on the contribution of framing system to the acoustical performance of glass. It demonstrates through a series of laboratory tests and parametric analysis the sensitivity of sound transmission loss of the framing elements, size, and configuration. Also, it introduces new mullion designs that mitigate sound using improved detailing and supplementary material. The interaction of these new concepts with other façade characteristics, such as thermal attributes has been examined. Enhancement of ancillary components such as spandrels and shadow boxes are also examined to explore their effect on the overall system performance.

PACS no. 43.55.+p

1. Introduction

The field of façade acoustics is the study of the behavior of sound and its human perception in buildings. It is classified as the evaluation and mitigation of disturbing or unwanted noise from sources outside the buildings. Even though the basic principles of sound wave propagation have been known since the late nineteenth century, the concept of sound control and evaluation is a relatively new topic of study. Most of the work was started in the early seventies, and the focus of work

has been on methods for evaluation and classification of sound transmission through various envelope components such as walls, floors, and doors. The early work has been commissioned by federal transportation and aviation agencies concerned with the noise pollution near highways and airports. Later these works were consolidated into a series of procedures published as ASTM and ANSI standards. These procedures mostly deal with testing and measurements.

Aluminum and glass curtainwalls are perhaps the most utilized façade systems in the commercial and residential high-rise buildings. They provide an effective means of creating transparent envelopes. While a significant effort has been expended to create energy-efficient curtainwalls, the acoustical consideration has always been treated as a secondary design requisite. However, new environmental regulations have focused attention on adverse health effects associated with unwanted and disruptive noise levels. These concerns have prescribed new limitations on the amount of noise transfer allowed through exterior walls. In turn, the institution of these new restrictions has initiated innovative designs.

The recent availability of double cavity insulated glass products, as well as the development of acoustical interlayers, has increased the acoustical property of the glazing systems significantly. Multi-layer glass strategies have also been employed to create more sound isolation, by creating large air pockets in-between the exterior wall and an auxiliary interior glass barrier.

Aluminum and glass have comparable stiffness and density properties, which gives them roughly matching acoustical characteristics. With this introduction of higher performing glass solutions, the framing elements become more critical for limiting the noise transfer. Additionally, the need for mechanical engagement of adjacent units requires a myriad of interlocking mechanisms that need to be elastic to accommodate imposed movements and temperature variations. The softer materials used in achieving these flexibilities, have a lower acoustical tolerance, which will create weaker sound paths, and compromise the effectiveness of the system to impede noise transfer. The following observation and experiments will try to highlight some of these features and propose guidelines for the implementation of designs which will enhance the overall acoustical performance of unitized curtainwalls.

2. Sound Transmission Through Fenestration

Figure 1 depicts the paths the sound transfers through building façade. Typically, there are three distinct paths. Sound transmits through the vision glass, the perimeter framing, and finally the opaque surfaces, such as shadowboxes or spandrel panels that conceal slab edges. Glass covers the bulk of the surface; therefore, it is the primary source of

sound energy transmission. Majority of vision glass types are composed of two glass layers with an airspace separation.

Aluminum framing, even though has a smaller exposed area, it is made of various cavities and often contains orifices for drainage and air circulation. Also, the extrusion wall thicknesses are frequently optimized to archive a minimum, while mechanical interlocking systems are employed to reduce field labor costs. All these factors can contribute to the degradation of acoustical performance of the overall barrier.

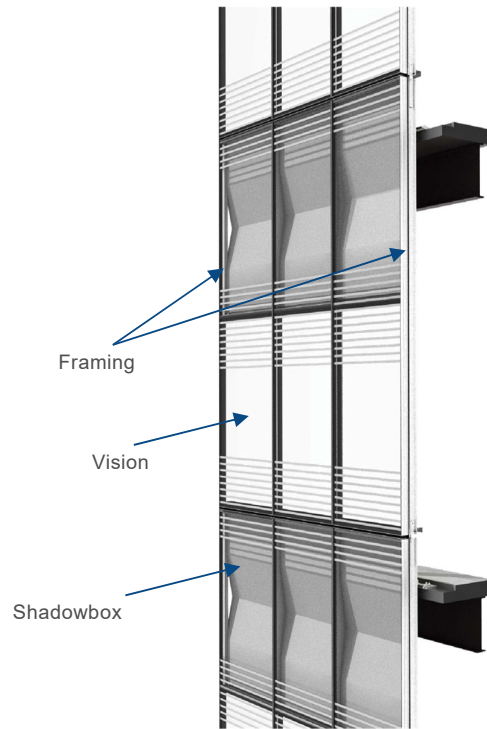

Figure 1. Sound Transmission through a typical unitized curtainwall system.

On the other hand, the opaque surfaces can be packed with multiple layers of sound absorbing material which can enhance the acoustical performance.

In the absence of test results, a close approximation to the System Transmission Loss (TL_s) can be computed by using the logarithmic average of individual components:

$$TL_s = 10 * \log \left[\frac{\sum_{k=1}^n a_k}{\sum_{k=1}^n a_k 10^{-\frac{TL_k}{10}}} \right], \quad (1)$$

TL_k are individual component transmission losses, and a_k are the component areas.

3. Glass Effects

Glass covers a significant portion of the exposed surface of modern buildings. Classically, the primary design requirements for glass has been dictated by thermal and lighting criteria. However, due to newer environmental restrictions in populated metropolitan areas, the acoustical performance of glass is becoming a vital measure in

the design of newer façades. The crucial parameters in the acoustic design for glass systems are glass thickness, number of layers and separating air space between the glass panels.

The use of panes with different thickness is a key enhancement in the TL in the mid-range frequency, especially around the coincidence frequency (Figure-2). Increased size of the airspace will shift cavity-resonance frequency and will result in better performance at the low-frequency range (Figure 3). The use of interlayers, in particular, acoustical interlayers, results in increased loss factors and an improvement in the high-frequency range. Finally,

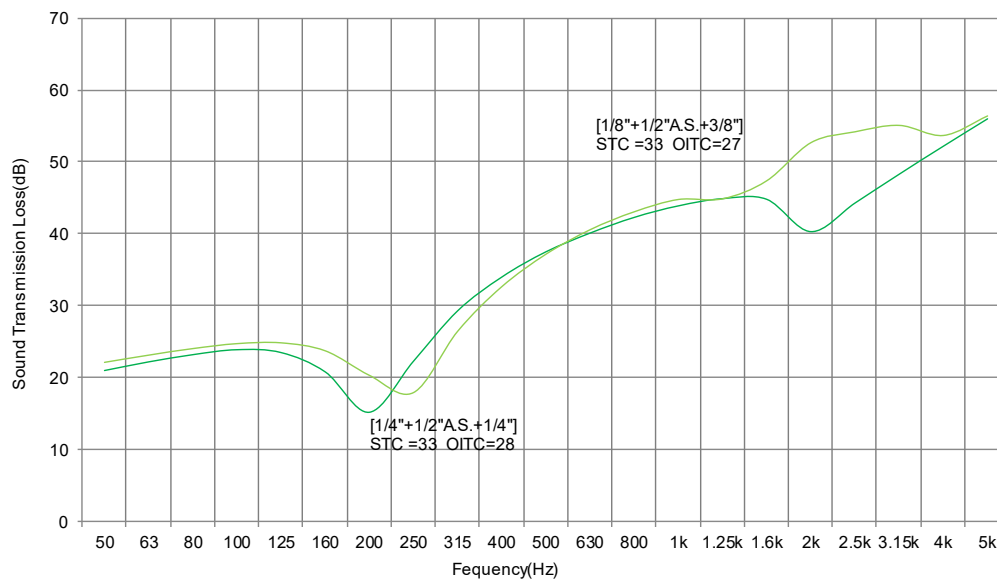

Figure 2. Sound Transmission Loss for insulated glass system with different thicknesses.

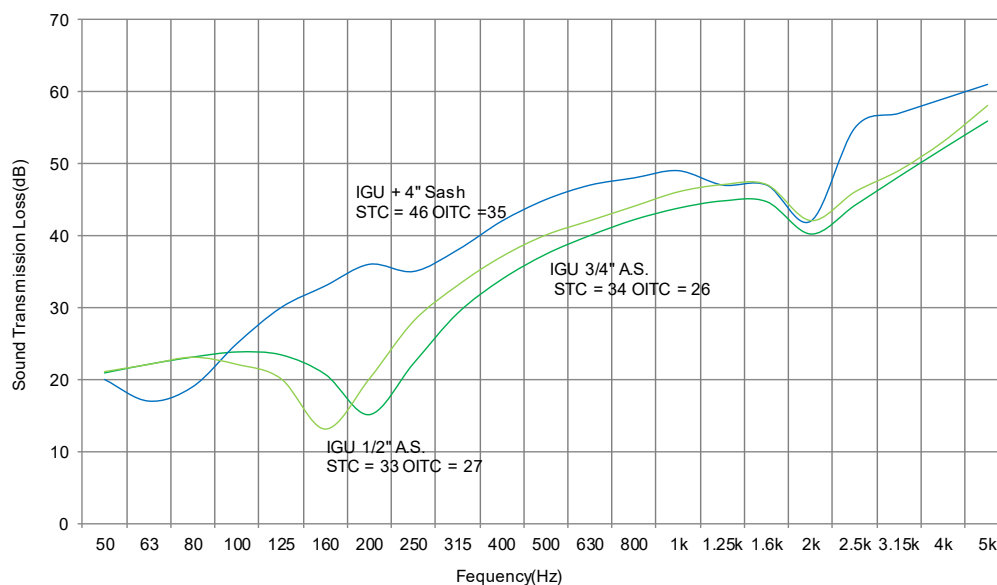

Figure 3. Sound Transmission Loss for insulated glass system with different airspace.

use of secondary cavities, such as sashes or double façades will be the ultimate in noise mitigation and sound control.

4. Framing Effects

The frame construction forms the load-carrying structure for glass and opaque units in a façade. Here, the structure of the frame profiles is essentially determined by structural, thermal insulation and weather tightness requirements. Additionally, the structure and shape of the façade profiles are also determined by the façade construction methods on the building site, integrated opening types, and design aspects.

Aluminum extrusions are usually separated with “nonconductive thermal isolators” to enhance their thermal performance significantly while maintaining the exterior appearance and retaining almost all the structural strength. Superior recycled content also adds to the appeal of aluminum products to meet the latest green building accreditation or certification.

Mechanical and physical property of glass and aluminum are similar. The coincidence frequency of aluminum is $f_c=12.0/t$ and for glass $f_c=12.7/t$, where t is the plate thickness in meters.

The difference is about 5%. This attribute results in a similar acoustical performance for both materials of identical thicknesses.

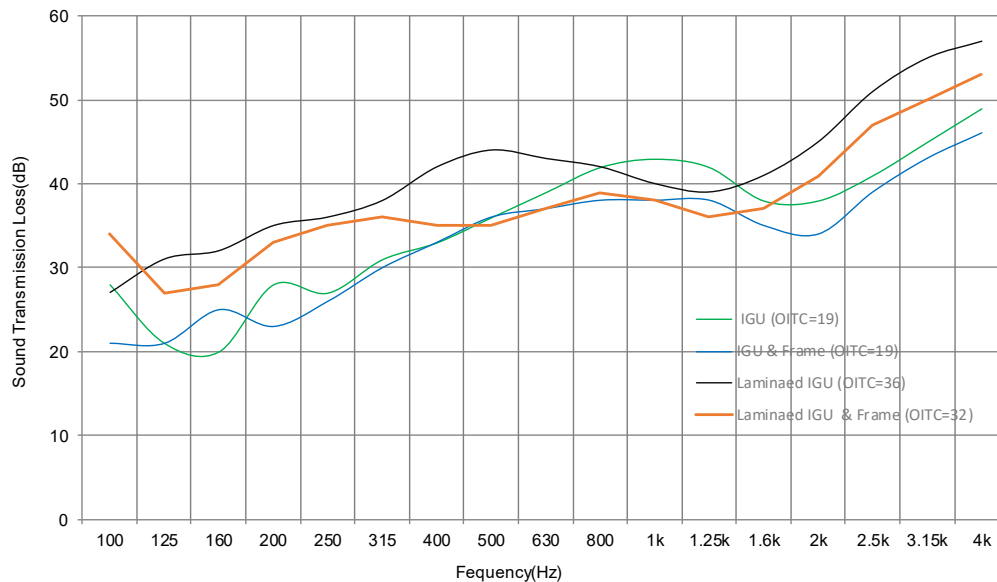

Figure 4. Comparision of Sound Transmission Loss for Insulated Glass Unit (IGU) with and without framing to a high permernance laminated IGU glazing System with and Without Framing.

The different types of frame construction have an impact on the sound transmission of an external façade. Aluminum extrusions have been the dominant choice for the framing of façade elements for modern and contemporary commercial and residential fenestration products. Aluminum provides good durability, high strength, low maintenance and relatively low purchase costs, compared to other framing material such as wood, PVC, fiberglass, composites, and steel.

Figure 4 illustrates the sound transmission loss for a framed and an unframed glass for a 24mm insulated glass unit made of two 6 mm glass panels with an air space of 12mm. This chart demonstrates the OITCs (outside inside transmission class) of the two specimens are identical. Hence the inclusion of the aluminum framing does not weaken the overall performance by any significance.

However, when the acoustical performance of the glass is enhanced, the same does not hold true. Figure 4 also shows the STL of a similar size glass panel of much superior performance, with and

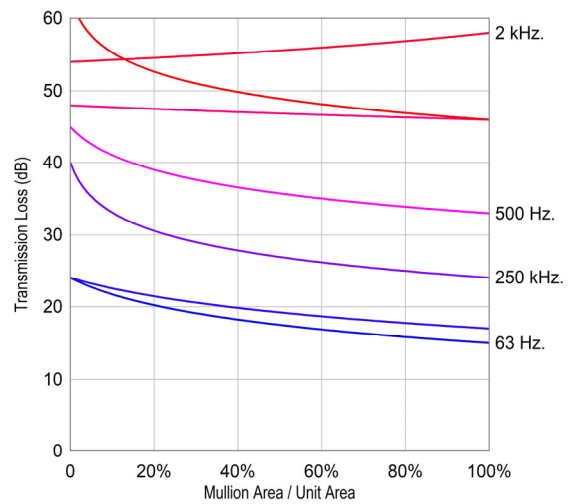
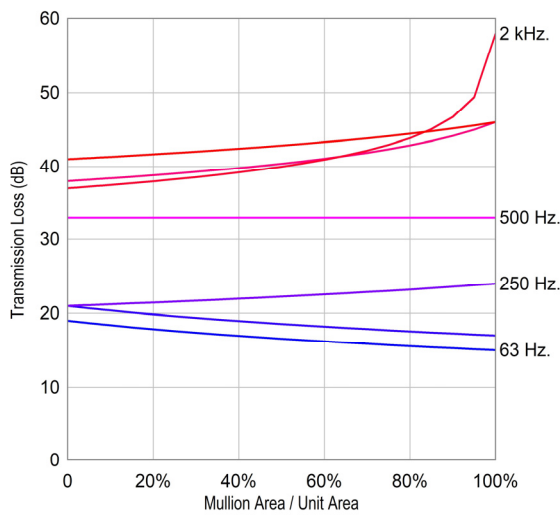

Figure 5. Effect of exposed framing area on the acoustical permance of a typical glass (left) and a high performing glass (right).

without framing effect. The glass considered is 50 mm thick made of a 10 mm outer layer glass 24 mm airspace and a 16 mm laminated glass inner layer. The framing remains very similar with the glazing pockets changed to accommodate the thicker glass. Here a difference of 4 dB in the OITC is witnessed. Figure 5 compares the effect of the exposed framing area for the two glass types. It is evident from these results that for typically exposed area ratios of 7% to 10% the framing effect has a much lower influence on the overall STL of the system.

5. Framing Enhancement

Although the importance of frame profile design with increased sound reduction requirements is known, sound reduction still plays a subordinate role in the structural design of frame profiles. The following will focus on two key aspects which merit attention in practice. Due to the frame proportion of 20-30%, the sound reduction effect of a façade is essentially determined by the glazing. With standard insulating glass and standard frame profiles, the weighted sound reduction indices R_w of both components are in the same range at 31-35 dB. If high requirements are placed on the sound reduction index of a façade, they can be met by using appropriate sound reduction glazing.

Figure 6 uses an example façade to show, that the frame becomes an even greater influence, if the sound reduction requirements increase. For the example façade with frame profiles, that have a weighted sound reduction index of 31 dB, a weighted sound reduction index of just 46 dB is achieved for the façade with a glazing of 50 dB. For the façade to meet sound reduction index specifications, knowledge of the sound reduction effect on the profiles used, is key to finding an economical solution.

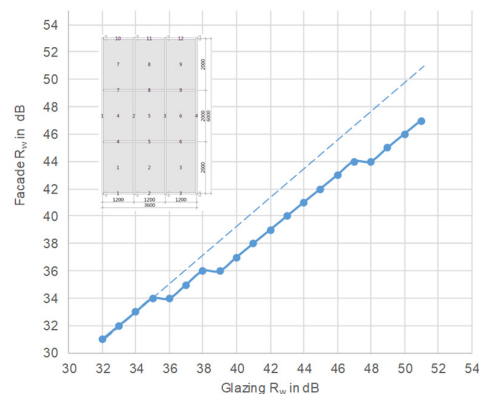

Figure 6. R_w for a façade element with up to 70 mm wide profiles depending on the glazing

To be able to achieve sound reduction requirements of 50 dB or more, the sound reduction of the frame profiles often needs to be improved too. Depending on the profile geometry and design of the façades, the hollow chambers of the profiles are filled with sound-reducing material. Depending on the requirement to be met, this could be plasterboard, steel plates or quartz sand. The effect is shown below using the example of wide frame profiles with a thermal break. Frame profiles with thermal break consist of two hollow aluminum profiles, that are fixed together with two plastic insulating profiles. Figure 7 shows a decline in the sound reduction effect with increasing profile width, using wide sash bar profile as an example.

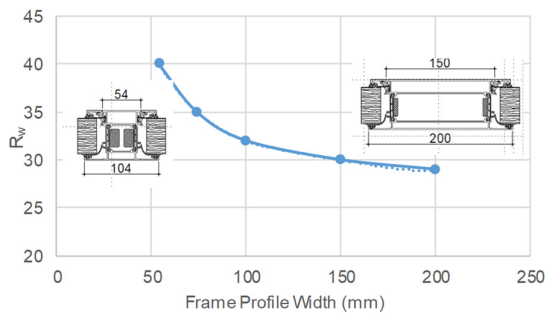

Figure 7. Weighted sound reduction index R_w for a sash bar profile

To be able to improve the sound reduction in a wide sash bar profile, it is recommended to fill the aluminum inner profile initially. Figure 8 shows the improvement using a 150 mm-wide sash bar as an example. 12.5 mm-thick pressed struts made from plaster and paper fibers were used as filling material. This modification led to an improvement in the weighted sound reduction index R_w of 9 dB compared to the unfilled profile. It is possible to make further improvements by filling the outer profile as well. In the example in figure 8, struts made from cement-bound calcium silicate were used to this end. This allowed a weighted sound reduction index R_w of 42 dB to be achieved for the 150 mm-wide sash bar profile. Figure 9 shows the measurement curves for the 150 mm-wide profile with and without optimum infill in the inner and outer chamber. Infills allowed the declines to be leveled out at 500 Hz, 1600 Hz, and 3150 Hz. The filling material then determines the course of the measurement curve across the frequencies.

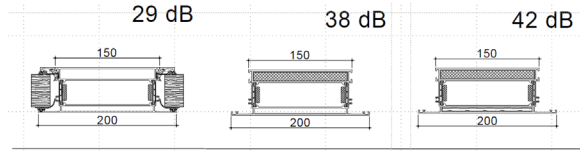

Figure 8 Improvement to the sound reduction index R_w by filling the aluminium profiles

Improving the sound reduction index of wide frame profiles depends on using filling material that not only has excellent sound reduction properties but can also be easily inserted in the small hollow chambers of a profile across the entire length of the frame construction. It must be noted here, that the frames are subsequently assembled to form a load-bearing structure, and there must not be any gaps in the fill areas during assembly. The façade unit in figure 10 shows how a frame profile improved with infill has a positive impact on the sound reduction in a façade. The 3 m x 3 m unit consists of three glazed fixed fields and is divided in the middle by a 150 mm-wide sash bar profile. The horizontal division on the left-hand side is made using a narrow sash bar profile.

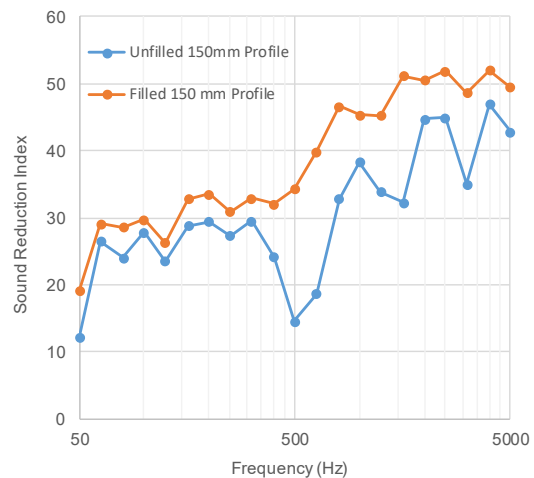

Figure 9. Comparison of the sound Reduction Index of a 150 mm profile unfilled and filled

In a façade unit like this one, the wide sash bar profile has a significant impact on the sound reduction index, that can be achieved for the entire unit. This means, that a weighted sound reduction index of just 41 dB can be achieved for the façade unit with 53 dB glazing. In contrast, if the sash bar

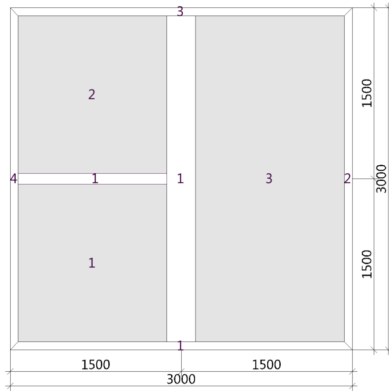

Figure 10. Example unit with wide 150 mm mullion profile

the profile is filled in the inner and outer profile chamber, a weighted sound reduction index of 47.5 dB can be achieved for the façade unit with 53 dB glazing. Figure 11 shows the weighted sound reduction index R_w for the unit with unfilled and filled sash bar profile, depending on the glazing used. When planning the sound reduction for façade units, it is very important to be aware of the effect of frame profiles to identify at an early stage individual critical profiles that need to be optimized and allow for this in the construction. In individual cases, identifying the potential improvement to frame profiles can lead to significantly more economical solutions for the façade unit, if more economical glazing with lower sound reduction can be used.

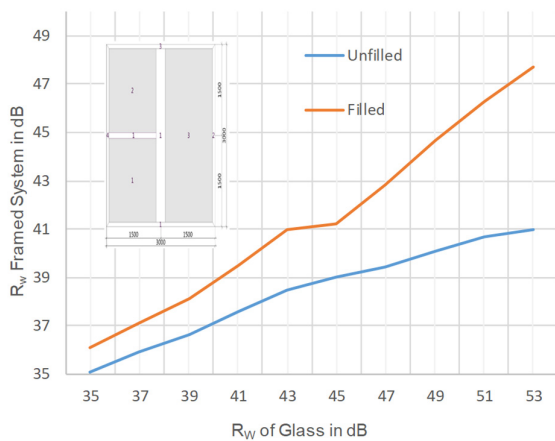

Figure 11. Weighted sound reduction index R_w for the example unit with and without improved mullion profile

6. Enhancements to Shadow Boxes and Spandrel Panels

Approximately 15% to 30% of curtain wall surfaces are “Spandrel or Shadowbox Panels” (SSP). The primary application of these types of opaque panels is to cover floor sightlines at slabs as well as other interface conditions. SSPs are essentially comprised of two planar elements defining a single interior cavity, or three planar elements defining twin interior cavities. The choice of material and panel makeup depends upon the functional requirements of the unit. The exterior surface of a spandrel panel is opaque glass or metal, while a shadow box uses transparent glass. Sheet metal or foil is used for the interior surfaces. Similar detailing is also utilized in the fabrication of back panels for stone and metal panel façades. Figure 12 shows a typical shadowbox design. This design uses a 24 mm exterior insulated glass unit, a 100 mm sealed cavity, a 4 mm aluminum panel, and a 100 mm foil back mineral wool insulation.

The cavity created by SSP’s presents an excellent opportunity to introduce sound deadening materials to improve the acoustical performance of the overall façades. Mineral wool improves TL at mid to high frequencies range, and mass load vinyl is very effective in low to mid-range frequencies. Figure 13 illustrates such a configuration. The comparison of the STL for metal panels with an empty cavity and the combination with mineral wool and MLV is presented in figure 14.

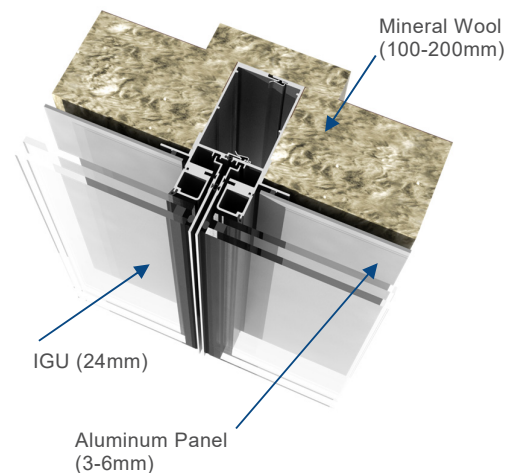

Figure 12. A typical shadow box employed in the construction of unitized curtainwalls

7. Conclusions

The demand for quieter fenestration products continue to increase for noisy metropolises, and utilization of more efficient material will need to be augmented by the introduction of more innovative and efficient designs. Manufacturers are rushing with new products to help builders, and designers to achieve higher levels of comfort for both residential and commercial constructions.

This study evaluated the effect of aluminum framing elements on the acoustical behavior of building façades. It demonstrated, that to be able to utilize the full benefits of the latest high-performing glass products, such as double insulated and laminated-insulated glazing, façade framing components will require improvements. Several solutions for enhancement of framing systems are introduced and their effectiveness analyzed. In particular effect of framing fills and the addition of mass loaded vinyl layers to spandrel and shadowboxes were studied. The result indicated a substantial improvement in both, sound transmission loss and the related sound reduction indices.

The proposed solutions are rather inexpensive and requiring very little redesign. Some can be incorporated into existing products with ease and little upfront investment. The utilization of these methods will result in a more balanced performance between the glass and framing elements.

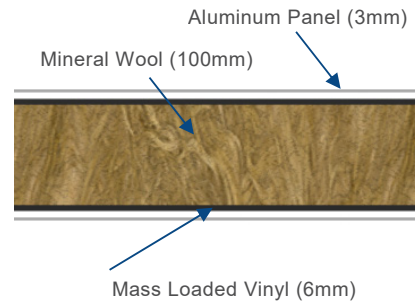

Figure 13. Use MLV to enhance the acoustical performance of shadow boxes

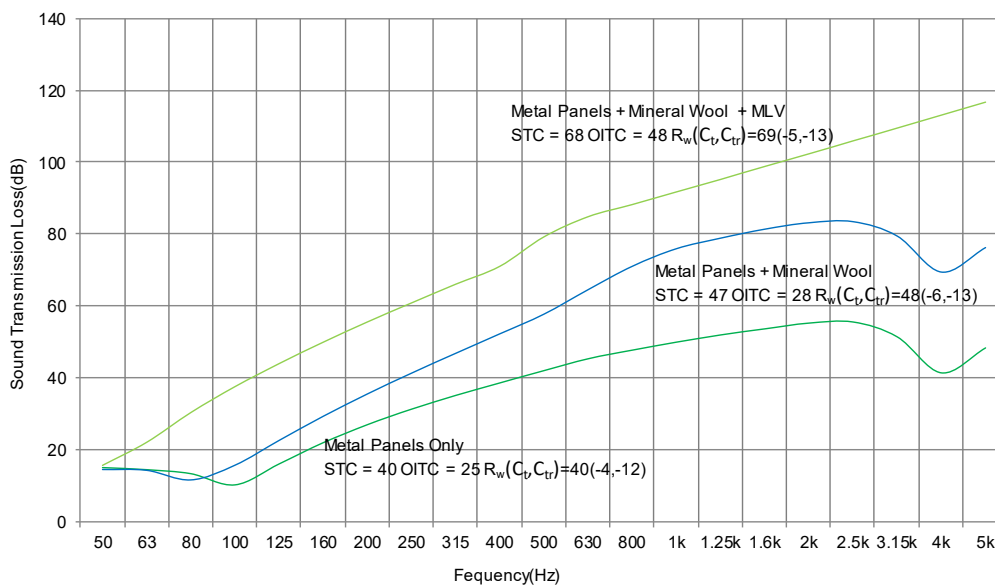

Figure 14. Sound Transmission Loss of a Spandrel Panel with Different Configurations