

technology on your wavelength®

VIBRATION ISOLATION FLOATING FLOORS

 **REGUPOL®** ACOUSTICS

REGUPOL-ACOUSTICS.COM

Vibration Isolation of Floating Floors

Regupol® Acoustics has developed a variety of floating floor products, available in multiple thicknesses with load range performance up to 362 psi. Regupol® Acoustics has a solution for any scenario.

For high airborne sound and vibration isolation:

Regupol® SoundPanel blocks sound and prevents noise from traveling between rooms. These products greatly improve the STC and IIC ratings of floor/ceiling assemblies.

For high impact and load applications:

Regupol® Vibration continuous roll material is recommended for high load and impact areas, such as commercial and industrial floating floors, fitness studios, loading docks, convention centers, and other areas, where discrete pad systems are not suitable. Great dimensional stability, high resilience, and durability make them the leading products in the area of heavy-duty floating floors.

Solutions for all kinds of applications:

- Convention and Exhibition Centers
- Performing Arts Centers and Stages
- Fitness Centers and Gyms
- Recording Studios
- Manufacturing Facilities
- Cinemas and Personal Theaters
- Bowling Alleys
- Rooftops
- Airports
- Schools and Colleges
- Laboratories



Regupol® SoundPanel



- 1 floating slab
- 2 polyethylene film
- 3 plywood or OSB (optional)
- 4 Regupol® SoundPanel
- 5 subfloor
- 6 Regupol® Perimeter Isolation Strip

Regupol® Vibration



- 1 flooring
- 2 floating slab
- 3 polyethylene film
- 4 Regupol® Vibration 200/300
- 5 subfloor
- 6 Regupol® Perimeter Isolation Strip

Regupol® SoundPanel

Regupol® SoundPanel is a panelized system designed to greatly improve the acoustics of a space by eliminating the transfer of sound between rooms. The system consists of a strong and durable OSB panel with noise insulating fiberglass attached underneath. Engineered rubber pucks support the panel with minimal contact between the subfloor and the rest of the assembly, while maximizing vibration absorption. The pre-manufactured one piece system is 4' x 4' making it easy to transport and install.

Regupol® SoundPanel is available in multiple styles and thicknesses to meet the demands of any project. The system can be used in combination with floating concrete slabs, floated hardwood flooring, Regupol® AkustiPro acoustical fitness flooring, and many other assemblies. An air gap and fiberglass insulation are implemented to provide superior airborne sound isolation, while maintaining a low structural height. The Regupol® SoundPanel design provides low constant natural frequencies, great sound absorption.

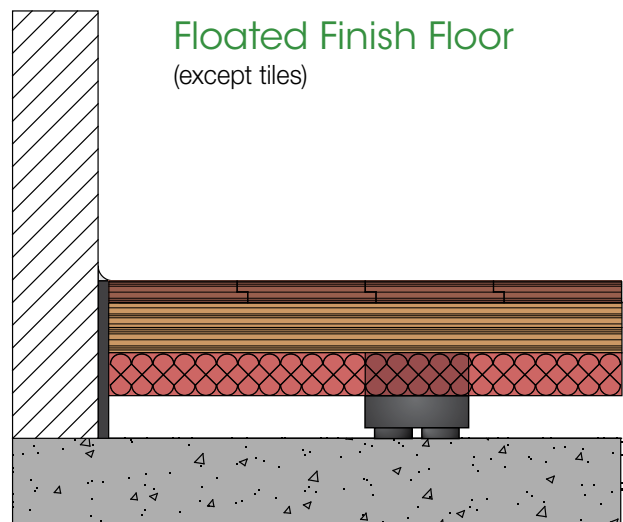
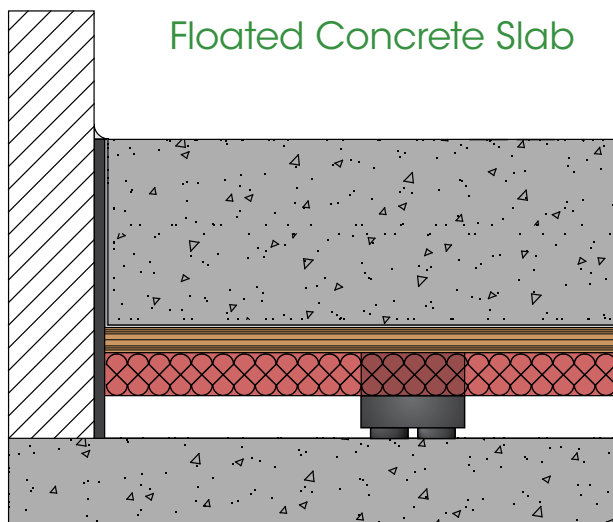

Test Results

Type	Natural Frequency	STC	IIC	ΔIIC
x4-1 (1")	14 – 15 Hz	69	68	39
x4-1.5 (1.5")	10.7 – 12 Hz	70	70	42
x4-2 (2")	8.8 – 11 Hz	71	72	43

Test Assembly

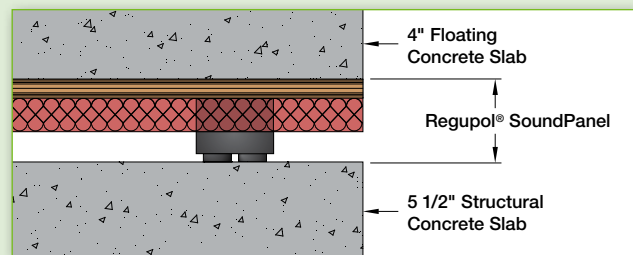

Features and Benefits:

- Multiple styles for any loading scenario
- Very low structural height required
- Quick and simple installation cuts labor costs
- Predetermined spacing prevents installation confusion
- Low and constant natural frequencies
- Great sound absorption
- As little as 0.67% contact area to subfloor

Regupol® Sound Panel

For the selection of the most appropriate Regupol® SoundPanel type, please refer to the product guide below. When deciding on a type you may want to consider the static load (dead load), dynamic load (live load), max allowable natural frequency, max system thickness, and required spacing.

*Note: SoundPanel with 16" spacing shown below:

Product Guide	
Floor Load	SoundPanel
0 - 0.75 psi	x4-24
0.75 - 1.75 psi	x4-16
1.75 - 3.00 psi	x4-12
3.00 - 5.00 psi	x9-16
5.00 - 8.00 psi	x9-12

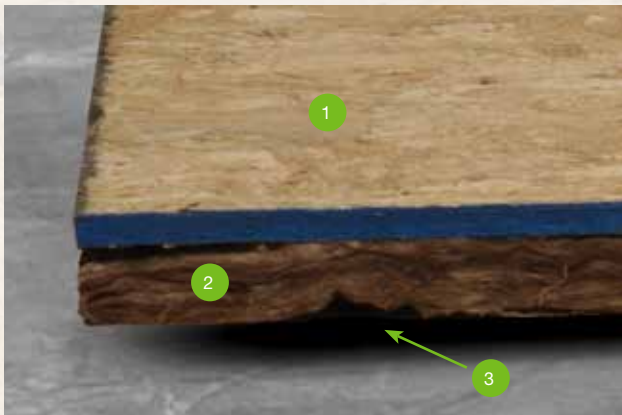
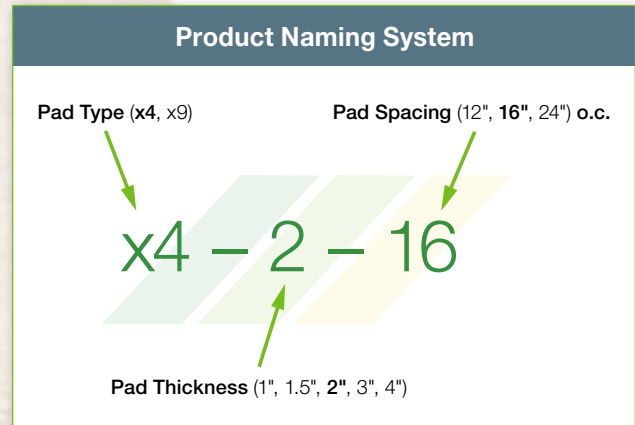

Features and Benefits:

- 1 19/32" OSB** for durability
- 2 1" Fiberglass Batt** for increased air-borne sound absorption
- 3 Regupol® SoundPad** dampens structure borne noise and vibrations

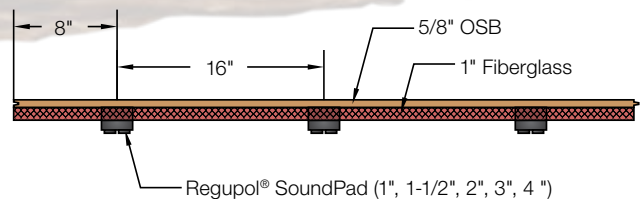
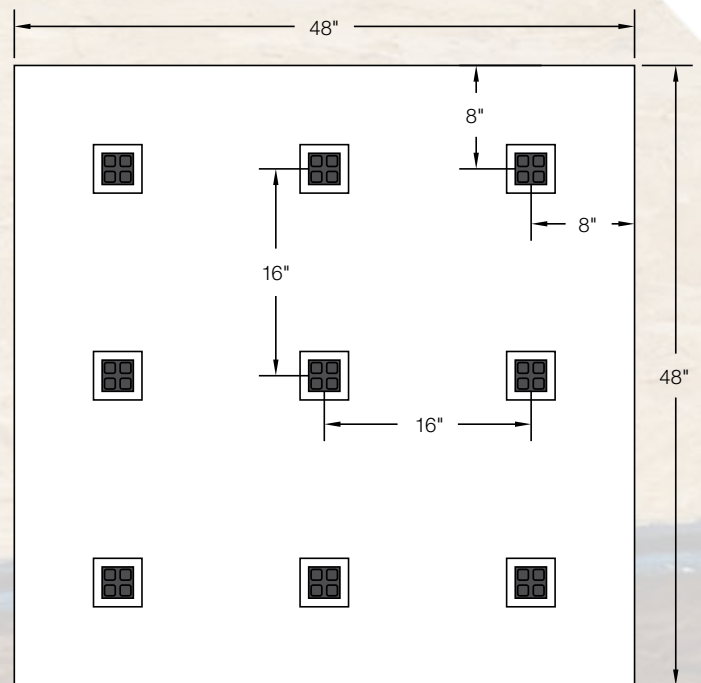

Regupol® SoundPanel x4 Series

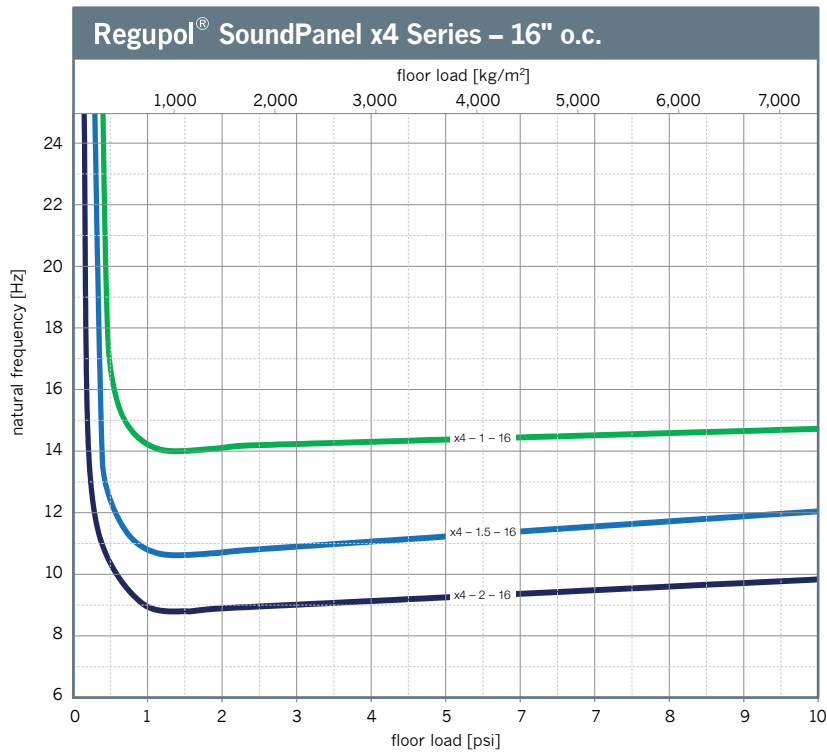
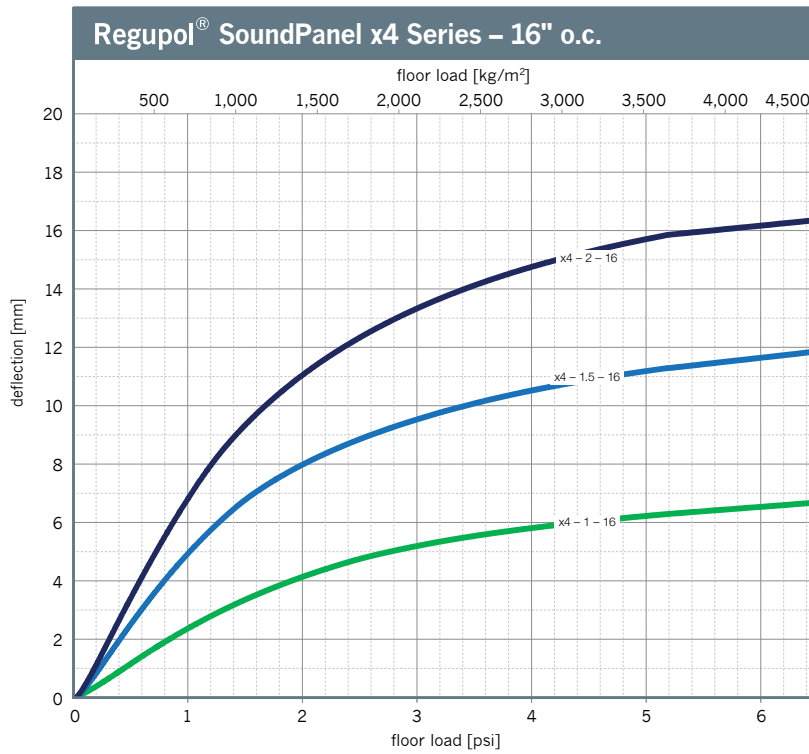

Regupol® SoundPanel x9 Series

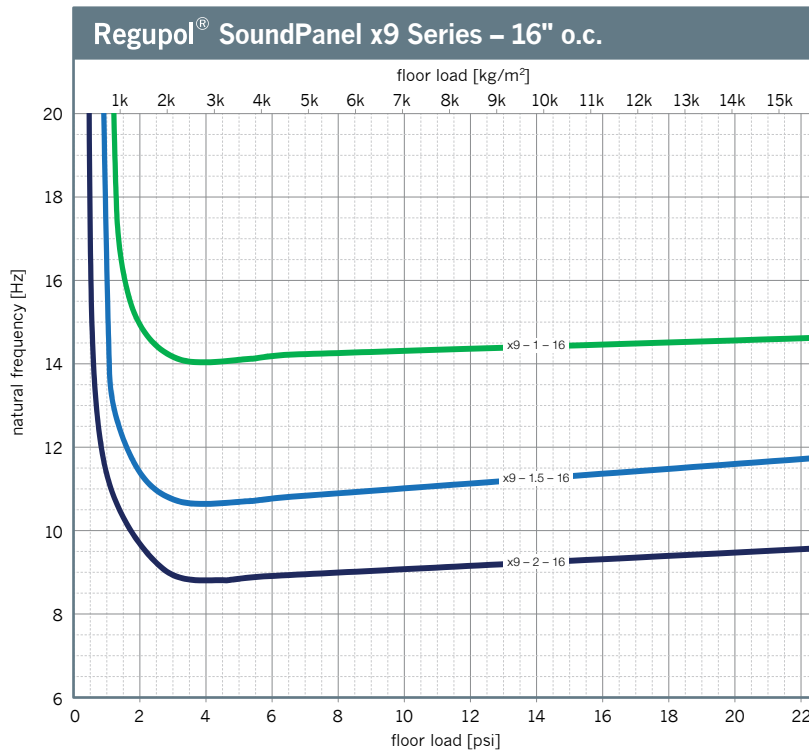
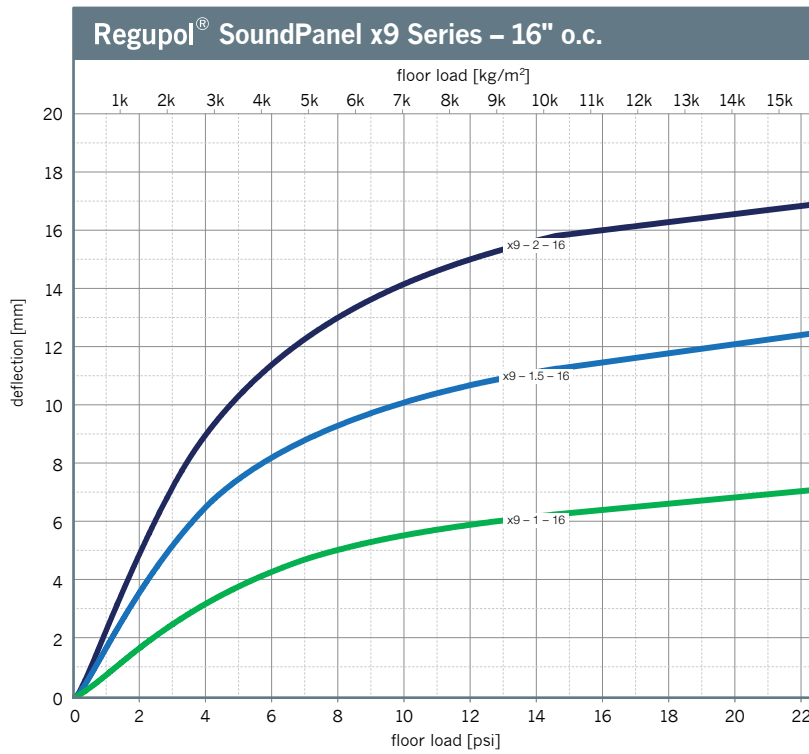

Regupol® SoundPad

SoundPad x4

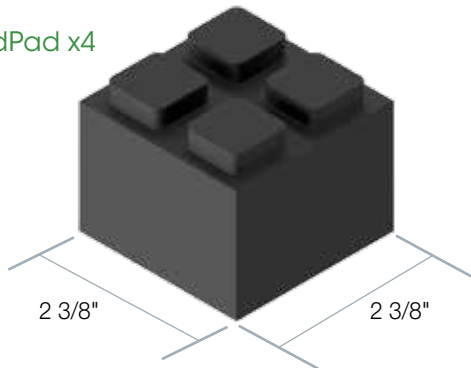

SoundPad x9

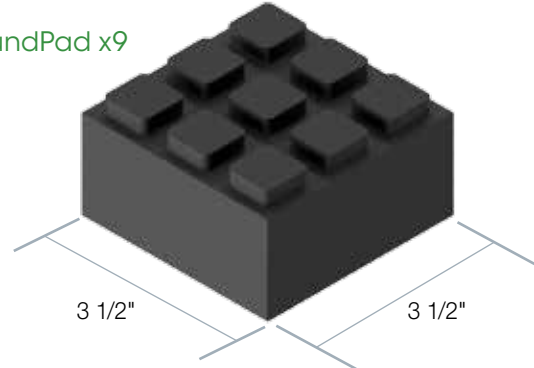

Regupol® SoundPad is an engineered rubber puck primarily utilized in floating floor assemblies to absorb vibration. The small squares on the underside of the SoundPad are designed to compress even under light loads to provide substantial vibration isolation and a low natural frequency. Regupol® SoundPad is used in the Regupol® SoundPanel system, but can be supplied separately and used in a wide variety of alternate assemblies. The SoundPads are available in two different sizes and multiple thicknesses; and can be placed at any desired spacing, depending on the needs of your assembly.

Regupol® SoundPads can achieve a natural frequency as low as 8.8 Hz at 2" thick, making it one of the highest performing products in the industry. The natural frequency of a system directly translates to isolation efficiency; usually the lower the natural frequency, the higher the isolation efficiency. Greater isolation efficiency simply means that the system will absorb and dissipate more vibrational energy.

SoundPad Advantages:

- Highly durable
- Water resistant
- Very low and constant natural frequency
- Great damping of vibrational energy
- Multiple thicknesses available: 1", 1.5", 2", 3", 4", custom
- Can withstand wide range of loads

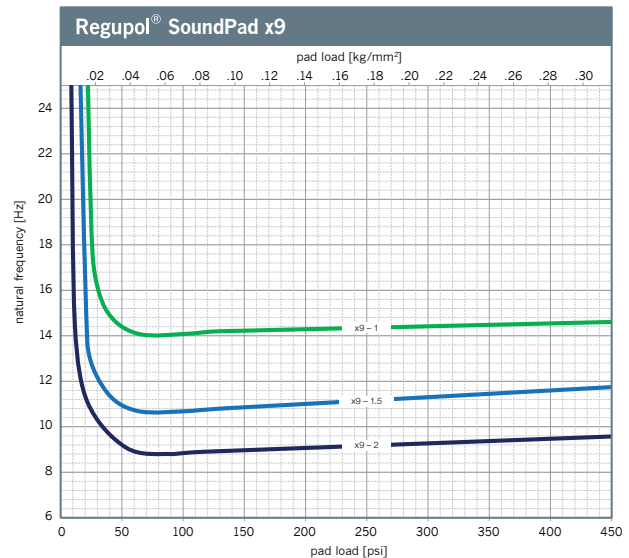
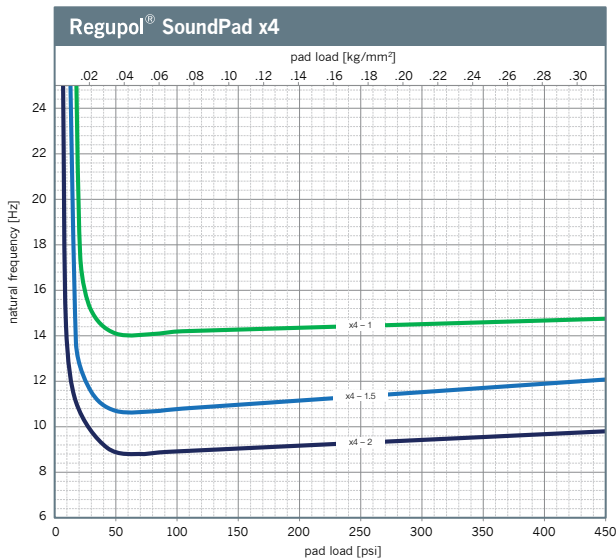

Continuous isolation for heavy loads and high impact areas

The Regupol® Vibration series is a lineup of multiple engineered polymer materials designed to eliminate the transfer of both airborne noise and impact noise.

Certain types of projects, such as convention centers, health and fitness clubs, or other commercial projects, may require a floating floor with durability and strength to endure high forces and heavy impacts. Regupol® Vibration Series can withstand a maximum static load of up to 218 psi and a short term peak load of up to 254 psi.

Benefits of continuous coverage with Regupol® Vibration include:

- Increased stability from full surface coverage and minimum deflection
- Low natural frequencies and high internal damping ensure superior sound isolation
- Rollout isolation material makes installation quick and simple
- Serves as formwork for floating concrete slabs

Impact noise isolation materials must be stable enough to withstand high loads, but soft enough to ensure sound isolation. Regupol® Vibration floating floor materials offer a high loading capacity, while providing excellent sound reduction due to its low dynamic stiffness.



Regupol® Vibration has unique characteristics that result in lower deflection values, even under high loads.

Excellent recovery properties under high loading and stress situations are required for permanent isolation effects and structural support. Regupol® Vibration products deflect under load, while providing excellent sound isolation, and almost return to their original thickness when the load is removed.

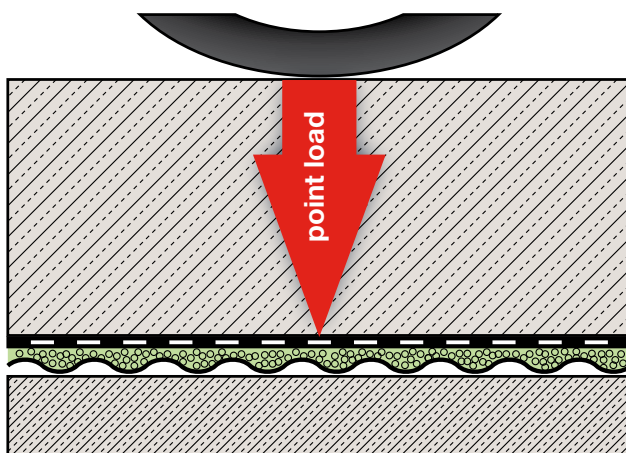

Regupol® Vibration can withstand very heavy loads and deflect without damaging the material.

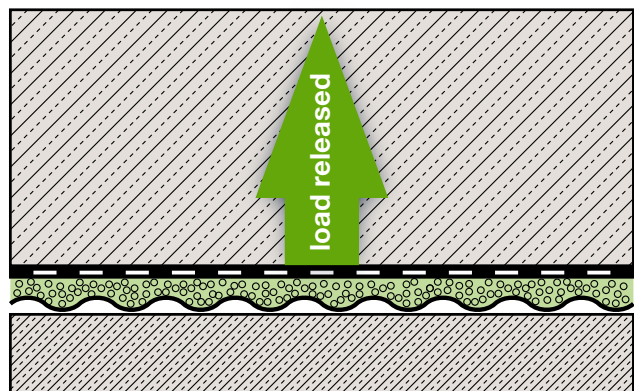

Regupol® Vibration products have excellent recovery properties and will almost return to their original thickness when the load is removed.

Regupol® Vibration 200 - Acoustical Performance

Higher density products are available for applications exceeding 2.9 psi max. static load. Please refer to the Regupol® Vibration Series data sheets.

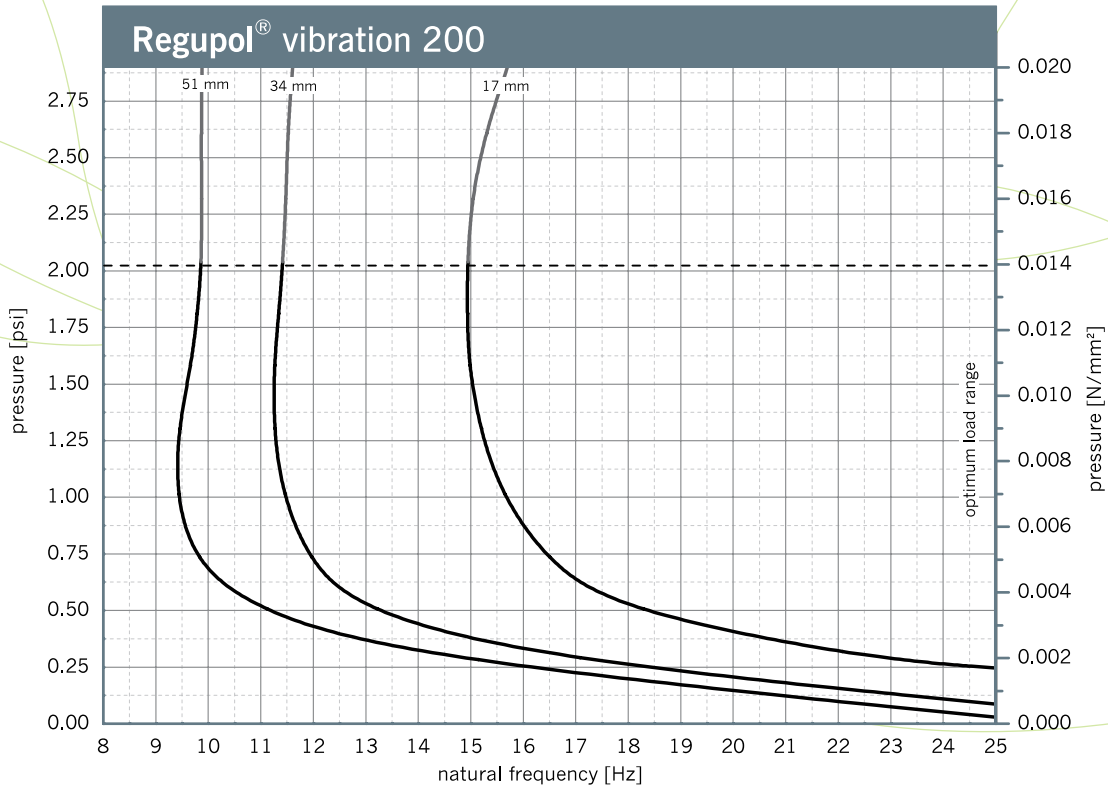

Natural frequency of a single-degree-of-freedom system (SDOF system) considering the dynamic stiffness of Regupol® vibration 200 on a rigid base. Dimensions of test specimens 300 mm x 300 mm.

Test Results

Natural Frequency	IIC STC
Regupol® Vibration 200 17mm (3/4")	IIC 64 STC 58
Regupol® Vibration 200 34mm (1-11/32")	IIC 65 STC 59
Regupol® Vibration 200 51mm (2")	IIC 70 STC 59

Test Assembly

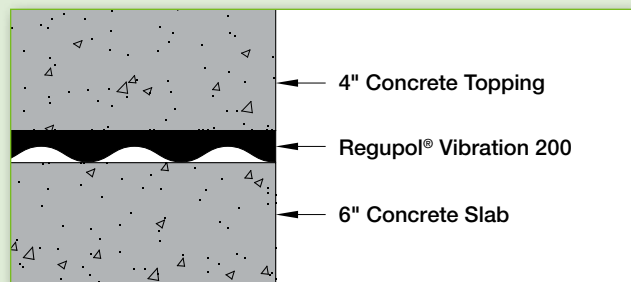



REGUPOL® AKUSTIPRO™

Regupol® AkustiPro patent pending

Regupol® AkustiPro is an engineered modular system designed to provide enhanced shock-absorption and structure borne sound isolation. The tile is PUR bonded, contains a patented wear layer for enhanced stability, and high damping components for outstanding vibration isolation in the low frequency range.

AkustiPro is commonly used for applications such as Olympic weightlifting, strength equipment, free weight areas, cardio equipment, and fitness studios.

AkustiPro can also be used in combination with the Regupol® SoundPanel or other floating floor systems as shown below.

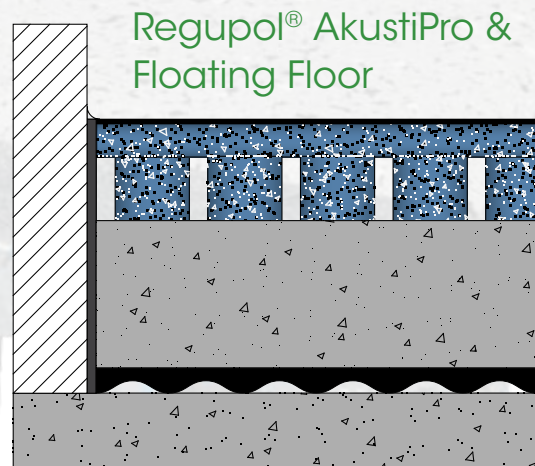
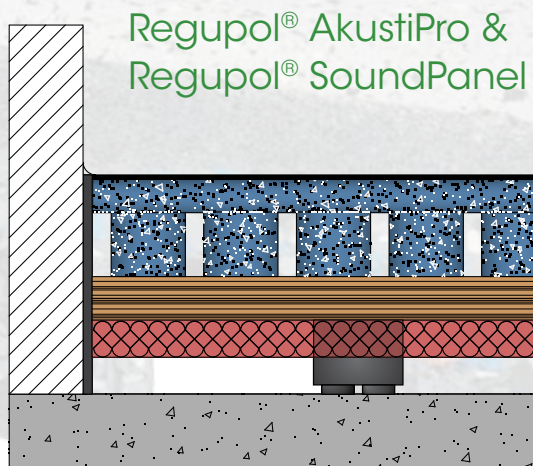



Features and Benefits:

- 1 high density wear layer** for durability, load distribution, and color quality. Various colors and designs available
- 2 high density SBR** recycled rubber for enhanced load distribution and stability
- 3 high-damping butyl rubber** for maximum energy absorption
- 4 fiber mesh interlayer** for dimensional stability
- 5 interlocking dowel system** for fast and easy installation
- 6 butyl pedestals with hollow core** for enhanced deflection and energy absorption, as well as reduced contact area
- 7 low dynamic stiffness rings** for enhanced deflection for low weight applications

For more information, please see the Regupol® AkustiPro brochure.

Please feel free to contact us for:

- Detailed technical information
- Calculations and recommendations
- Custom solutions for your individual project
- Installation instructions

Phone +1 800.537.8737 x119

Email acoustics@regupol.com



VIBRATION ISOLATION FLOATING FLOORS

information at: regupol-acoustics.com

 **REGUPOL®ACOUSTICS**

Download or request
additional information about
the Regupol® family of Sound Control,
or Vibration Isolation products at
Regupol-Acoustics.com

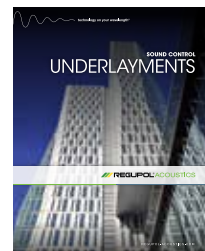
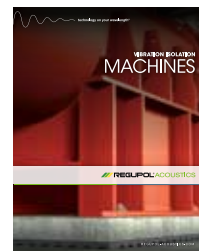

The information and data contained herein are based on industry accepted testing, manufacturing tolerances and prior product usage as set forth. It is intended as descriptive of the performance characteristics and capabilities of Regupol/Regufoam and does not certify applicability for any particular or specific project. Technical assistance, calculations and design recommendations are available from Regupol® America, and are subject to terms and conditions provided upon request.