

VARIABLE ACOUSTICS IN A REVERBERANT ROOM: COMPARISON BETWEEN PHYSICAL AND NUMERICAL APPROACHES

Cesare-Consumi, Marco; Tronchin, Lamberto; Tarabusi, Valerio

DIENCA – CIARM University of Bologna Viale Risorgimento, 2 I-40136 Bologna, Italy
Tel: +39.051.2093281; Fax: +39.051.2093296;

PACS REFERENCE: 43.55.Fw

INTRODUCTION

In the design of Opera Houses and Concert Halls, variable acoustics could be really useful, since musical performances require peculiar sound behavior of the architectural environment. The typical acoustical resonance of sound boards and sound chests of musical instruments, accomplished with resonance of the acoustic space, could definitely improve sound quality both in the audience area and in the stage. Furthermore, a proper design of resonators could solve problems related with lack of partials or focalization, that very often characterize many concert halls.

In this paper, a comparison between scale model, FEM and numerical models has been undertaken and applied on a reverberant room.

The acoustical behavior of a scale model has been analyzed by considering 200 resonators with circular section and with a variable room each, positioned on three different surfaces of the model. FEM and numerical analyses of the reverberant room were undertaken, and compared with experimental measurements in the physical model. Both from experimental and numerical evaluations, the following results were found.

- A single resonator that for his frequency could absorb about 11 dB, changing his room, the same resonator could emphasize the same frequency of 16 dB.
- A couple of resonators located in different points of the scale model, absorbed in a very different way, or to be precise, for absorbing the same frequency they had to change their room.

THE DIFFERENT APPROACHES

The calculation of acoustical parameters in a reverberant room, which is characterized by a regular shape and strong reflecting surfaces, is not a simple question. The reverberant

room allows the measurements of different absorbing coefficient by opening the chamber of the resonators, but many difficulties are related with the calculation of sound distribution, both in physical and in numerical models. In the first case, in order to obtain a reasonable frequency response in the measurements, a miniaturized sound source and a couple of microphones are required. In the second case, typical wavelike behavior of sound field are usually neglected, like diffusion and scattering, whilst atypical behavior (i.e. flutter echoes) are excessively emphasized. FEM model, therefore, which properly considers wave theory propagation, is required. These considerations have led to analyze variable acoustics in a reverberant room by considering three different approaches: physical, numerical and FEM modeling. The preliminary results of the research, mainly related to the sound distribution in the model (strength), are presented.

THE MODEL OF REVERBERANT ROOM

The model of a typical reverberant room was analyzed, both in the physical scale model and in the numerical wire-frame. The aluminium scale model (1/8) of the reverberant room has been realized in the following dimensions:

height:	m 0,62
width:	m 0,78
length	m 0,98

Therefore, the model had a Volume V of 0.41 m^3 and a Total Area of 4.78 m^2 .



Fig. 1 – the scale model

The resonators were designed paying particular attention to their absorption frequency, that should be variable from 700 Hz to 1400 Hz, by means of changing their variable room, and a definition level, Q factor, about of 1/12 octave. Therefore, the dimensions shown in fig. 2 were chosen. A wide area, among three different surfaces of the room, was covered with a great number of resonators, able to modify sound absorption and sound distribution over the entire floor.

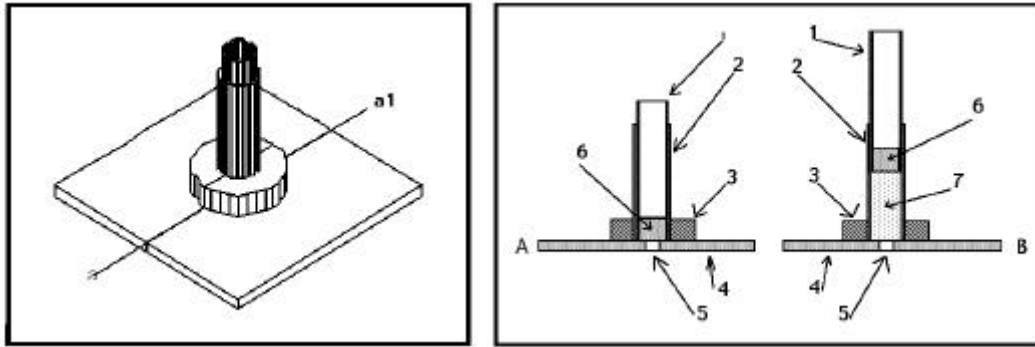
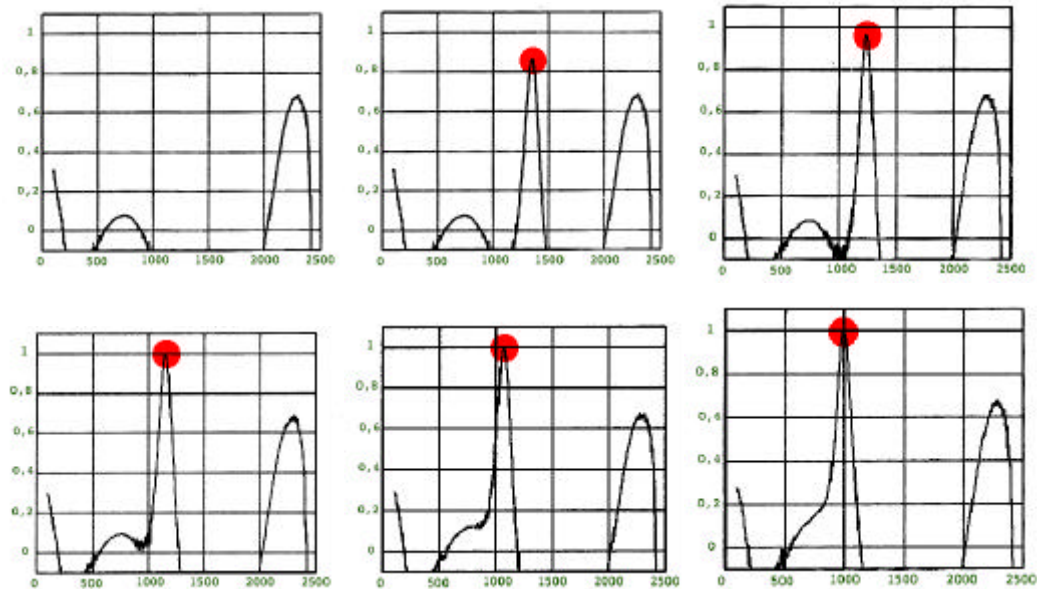

Fig. 2: Variable room resonator: isometric and cross section view

The reverberant room was analyzed both with a numerical, pyramid code and a FEM code. The wire frame of the reverberant room was built, and the model was properly calibrated, as shown in [6].

ACOUSTICAL MEASUREMENTS IN THE RESONATORS

After the realization of the resonators, a measuring campaign was undertaken in order to quantify both the absorption coefficient for each resonator, and the variation of frequency caused by the opening of the resonators and therefore the dimension of the variable room. The measurements of the absorption of the resonators (built by a sliding copper duct, aluminium slab and cylinder, and a trimming rubber) were conducted with standard ASTM C 384-95 [1].



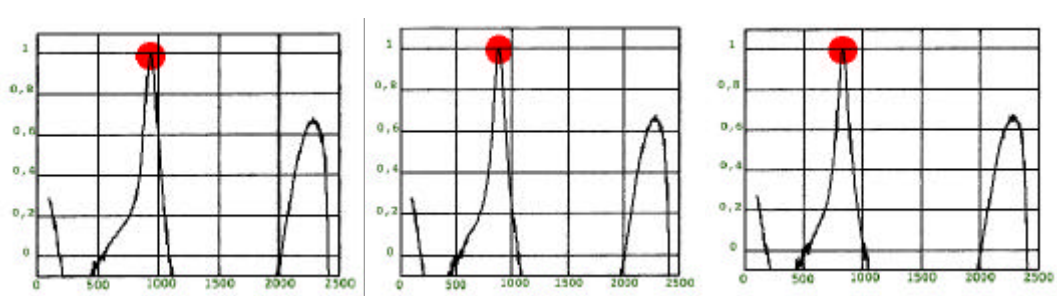

Fig. 3: Opening the chamber, the frequency resonance decreases from 1400 to 870 Hz

The absorption coefficient between 2k and 2.5k Hz, more evident with the variable resonator in closed position and represented in the first picture, in the left side, is due to the aluminium slab absorption. In the following pictures the absorbing coefficient is represented.

Frequencies (Hz)	absorption coefficient
1350	0,86
1250	0,95
1135	1
1065	1
1000	1
935	1
870	1
820	1

Tab. 1: Values of absorption coefficient from 1400 to 870 Hz

ACOUSTICAL MEASUREMENTS AND CALCULATIONS IN THE MODELS

Measurements of IRs were performed inside the scale model, by means of an omnidirectional sound source and a couple of miniaturized microphones. The experiments were conducted with the resonators in the closed positions. A sine-sweep signal was generated, and by means of a multi-channel sound-board (Layla, by Event) the IRs were measured in 40 different measuring points [2]. In a following step, the *strength* (G) was calculated in third-octave band, and represented in a bi-dimensional map.

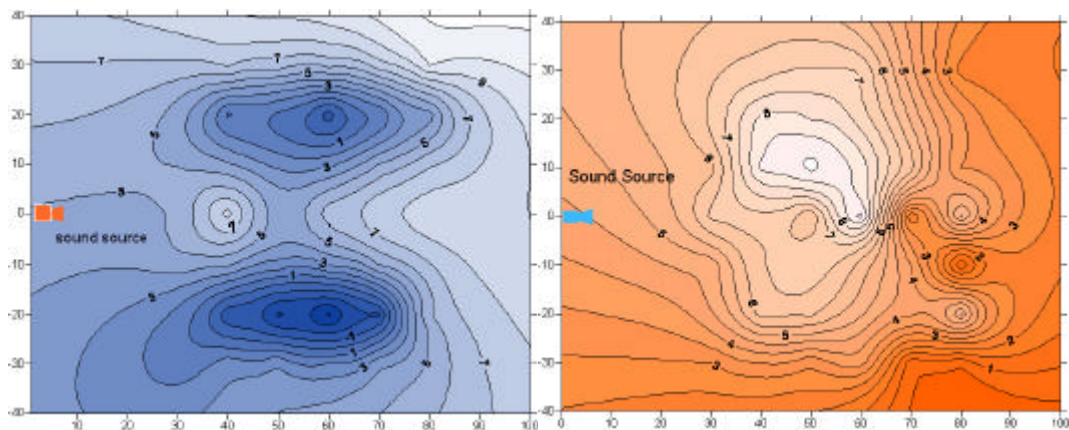

Fig. 4: spatial distribution of strength (G) at 500 Hz (left) and 8 kHz (right): close position

The acoustical behavior of the scale-model has been analyzed and compared with the numerical and FEM model. Preliminary results are now presented, since at the present day only sound distribution (i.e. strength) was calculated in the numerical approaches.

The last measurements were conducted by means of a pure tone, generated by the sound source, and positioning the microphones in the same positions as explained above. Many test signals were utilized. In a first step, a single pure tone was used, and the microphone was positioned a different height. In a second step, a multiple pure tone signal was generated, in order to check the behavior of the resonators with reference to a more complex sound source, like during a musical performance. The experiments pointed out a stronger absorbing coefficient with a single pure tone, but with multi pure tones a strong absorbing coefficient was still present. Similar results were found also by Franzitta [3]. The results are summarized in table 2.

A) pure tone frequency: 1000 Hz

- pressure level (measured with photometer): 77 dB
- result: the pressure level decrease from **77 dB to 24.6 dB**

B) 6 pure tones frequencies: 1000 Hz, 1100 Hz, 1180 Hz, 1260 Hz, 1340 Hz, 1420 Hz

- results: (measured with spectrum analyzer):
- 1000 Hz: from -12 to -17 dB = 5 dB decrease level
- 1100 Hz: from -10 to -15 dB = 5 dB decrease level
- 1180 Hz: from -12 to -40 dB = **28 dB** decrease level
- 1260 Hz: from -9 to -13 dB = 4 dB decrease level
- 1340 Hz: from -9 to -14 dB = 5 dB decrease level
- 1420 Hz: from -9 to -33 dB = **24 dB** decrease level

Table 2 : variation of sound energy inside the model, with single and multi pure tones

DATA ANALYSIS

Analyzing the results of measurements in the scale model, a strong absorbing coefficient in some positions and a great influence of the variable room resonator, not very evident in numerical models, was found. The analysis of measurements performed by means of pure and multi tones, a stronger influence of the wall at the opposite side (respect to sound source) in the scale model was found, whilst the lateral walls were found less absorbing.. Strong focalizations were found in the models, by considering the spatial distribution of strength (G) calculated after measurement and simulation of Irs. Furthermore, different results were found by changing the dimension of the variable room resonator. The influence of the resonators were found stronger in the positions far from the sound source, were strong influence of the dimension of the room were found especially at 500 Hz and 1kHz.

CONCLUSIONS AND FUTURE REMARKS

The sound quality in a concert hall could be strongly improved by means of the design of a proper set of variable resonators. The benefits of the resonators are strongly evident whenever focalizations are found, mainly due to the particular shape of the concert hall [5]. Furthermore, the proper design of variable resonators could definitely improve sound quality and spatialization in concert halls, whenever musicians require a better sound balance and blend. Moreover, during a performance, the sound characterization of the hall could be quickly modified. In this paper the behavior of a particular set-up of resonators was studied, by means of modeling a reverberant room both in physical and numerical approaches. Measurements of absorbing coefficient of the resonators, sound distribution and strength, by opening the variable room resonator, revealed a decrease of sound level in some particular positions of more than 50 dB. In some cases, a little opening of some specific resonators could give a strong modification of sound distribution (strength) and sound absorption, in a very particular position and frequency. The realization of variable room resonator, hence, could provoke a strong modification of acoustics of the hall, as required by many modern composers.

ACKNOWLEDGEMENTS

The Authors wish to thank the METRIC HALO of New York, USA (Dan Metivier) and EMKAY of York, UK (Darren Whittaker) for the material and the substantial help they gave us for the acoustical measurements in the scale model.

Work partially supported by Italian funding.

REFERENCES

- [1] Standard ASTM C 384-95: *Standard Test Method for Impedance and Absorption of Acoustical Materials by the Impedance Tube Method*, ASTM Philadelphia
- [2] A. Farina, L. Tronchin: *3D Impulse Response measurements on S. Maria del Fiore Church, Florence, Italy* Proc. of 16th International Congress on Acoustics, Seattle, USA, 1998
- [3] G. Franzitta (et al.): *Simulazione con modello in scala 1/8 delle prestazioni acustiche di una camera riverberante* 1981 - Quaderni dell'Istituto di Fisica Tecnica dell'Università di Palermo.
- [4] P. Fausti, A. Farina: *Acoustic measurements in opera houses: comparison between different techniques and equipment* Journal of Sound and Vibration, **232**(1) 213-229, 2000
- [5] Knudsen & Harris: *"Acoustical Designing in architecture"* 1980 – Columbia University.
- [6] A. Cocchi, A. Farina, L. Tronchin: *Computer assisted methods and acoustic quality: recent restoration case histories*, *Invited paper*, International Symposium on Music and Concert Hall Acoustics, (MCHA95), Kagoshima, Japan, 1995.